

CARBOHYDRATE-MODULATED GENE EXPRESSION IN PLANTS

K. E. Koch

Plant Molecular and Cellular Biology Program, Horticultural Sciences Department,
University of Florida, Gainesville, Florida 32611

KEY WORDS: catabolite repression, metabolite-regulated genes, photosynthate partitioning,
source/sink relations, sucrose

ABSTRACT

Plant gene responses to changing carbohydrate status can vary markedly. Some genes are induced, some are repressed, and others are minimally affected. As in microorganisms, sugar-sensitive plant genes are part of an ancient system of cellular adjustment to critical nutrient availability. However, in multicellular plants, sugar-regulated expression also provides a mechanism for control of resource distribution among tissues and organs. Carbohydrate depletion upregulates genes for photosynthesis, remobilization, and export, while decreasing mRNAs for storage and utilization. Abundant sugar levels exert opposite effects through a combination of gene repression and induction. Long-term changes in metabolic activity, resource partitioning, and plant form result. Sensitivity of carbohydrate-responsive gene expression to environmental and developmental signals further enhances its potential to aid acclimation. The review addresses the above from molecular to whole-plant levels and considers emerging models for sensing and transducing carbohydrate signals to responsive genes.

CONTENTS

INTRODUCTION	510
CARBOHYDRATES AS SUBSTRATES AND SIGNALS	510
<i>Biological Significance</i>	510
“FEAST AND FAMINE” RESPONSES AT THE GENE EXPRESSION LEVEL	511
<i>Carbohydrate Depletion and Sugar-Responsive Genes</i>	513
<i>Carbohydrate Abundance and Sugar-Responsive Genes</i>	516
<i>Contrasting Response Classes Among Genes for Sucrose Metabolism</i>	518
IMPLICATIONS AT THE CELL AND ORGANISM LEVEL	519
<i>Carbohydrate-Responsive Genes and Long-Term Metabolic Changes</i>	519
<i>Carbohydrate-Responsive Genes, Assimilate Partitioning, and Development</i>	521
<i>Interactions with Developmental and Environmental Signals</i>	524
CARBOHYDRATE-SENSING SYSTEMS	525
<i>Hexose Phosphorylation and Protein Kinase Cascades</i>	526
<i>Plasmamembrane Transfer</i>	527
<i>Key Metabolites as Direct Signals</i>	530
CLOSING COMMENTS	531

INTRODUCTION

In plants and microorganisms, sugars not only function as substrates for growth but affect sugar-sensing systems that initiate changes in gene expression. Both abundance and depletion of carbohydrates can enhance or repress expression of genes. Responses vary depending on the carbohydrate, though metabolic flux may be more important than actual levels of carbon resources. Many sugar-modulated genes have direct and indirect roles in sugar metabolism, which suggests that their altered expression may have adaptive value. Not only do collective, long-term changes in metabolism result, but patterns of carbohydrate allocation among plant parts can also be altered.

The existence and potential importance of sugar-regulated gene expression in plants has become apparent only in the past few years. Previous evidence indicated that sugar supplies could alter enzyme activities, metabolism, and development, but these data and their significance were generally not viewed in the context of gene expression. Initial work on photosynthetic genes and their metabolic effectors is reviewed by Sheen (161) and discussed by Stitt et al (175). Thomas & Rodriguez (187) summarize metabolite regulation in cereal seedlings and further appraise the germinating cereal seed as a model system (188). Koch & Nolte (84) relate advances in sugar-modulated gene expression to effects on transport paths. Classical aspects of altered carbohydrate availability on whole-plant and organ processes are appraised by Farrar & Williams (34) and Wardlaw (199), with updates by Geiger et al (43), Quick & Schaffer (139), and Pollock & Farrar (134). Information on sugar-responsive gene expression is also available for microbial (15, 40, 150, 158, 192) and animal systems (195).

CARBOHYDRATES AS SUBSTRATES AND SIGNALS

Biological Significance

In microbes, carbohydrate signals to sugar-responsive genes provide a way for these organisms to adjust to changes in availability of essential nutrients. This capacity is vital to their survival and/or effective competition. Classic examples include control of the lactose operon in *Escherichia coli* and the glucose responsive genes for sugar metabolism in *Saccharomyces cerevisiae* (15, 40, 150, 158, 192). Similar responses have more recently been identified in unicellular algae (9, 93, 155, 172).

In multicellular organisms, however, acclimation to altered carbohydrate availability occurs within a complex structure. Sugar-regulated genes provide a means not only for integrating cellular responses to transport sugars (carrying information on carbohydrate status of the whole) but also for coordinating

changes in resource utilization and allocation among parts. In addition, carbohydrate-responsive genes can effect changes in organismal development.

For plants in particular, carbohydrate-regulated genes represent an especially valuable mechanism for adjusting to environmental change. Plants are extremely sensitive and responsive to their surroundings because immobility leaves them few options for survival other than acclimation. Sugar concentrations vary over a wide range in plant tissues. This range typically exceeds that found in more homeostatic systems (such as the mammalian blood stream) and provides plants with both a broader range of signals and a greater challenge to adjustment. Sugar-mediated changes in gene expression are also unique in plants because changes in carbohydrate allocation can ultimately modulate form through processes affecting import/export balance (photosynthesis vs utilization).

Effects of carbohydrate availability on expression of specific genes may complement and amplify the influence of more immediate metabolic controls. Although gene-level responses are slower, they provide a magnitude and duration of change that cannot be accommodated by other means of regulation. The signals and regulatory mechanisms controlling the two processes appear to be quite different.

“FEAST AND FAMINE” RESPONSES AT THE GENE EXPRESSION LEVEL

“Feast and famine” is used here in a relative context and is not necessarily based on absolute levels of carbohydrate (see section on Carbohydrate-Sensing Systems). In the same way, “sugar-modulated,” “carbohydrate-responsive,” and “metabolite-regulated” gene expression are broadly inclusive. Transcriptional regulation is usually implied and is substantiated in many instances (77, 89, 160, 161), but message stability and turnover can also be involved (162). In any case, the ultimate effects of altered mRNA levels depend on the efficacy of translation, turnover and/or modification of protein products, and the metabolic context into which such changes are introduced.

The overall theme of Tables 1 and 2, together with discussion of salient features in this section, is that of carbohydrate-responsive gene expression as a mechanism for plant adjustment to altered availability of this essential resource. Known examples of sugar-responsive gene expression are organized by carbon-exporting and -importing tissues to help clarify the potential of their collective relevance to each. In general, carbohydrate depletion enhances expression of genes for photosynthesis, reserve mobilization, and export processes (Table 1), whereas abundant carbon resources favor genes for storage and utilization (Table 2). These effects, summarized schematically in Figure 1, reinforce the suggestion that sugar-responsive genes provide a means of adjusting whole-plant resource allocation and may ultimately contribute to adaptive changes in form.

Table 1 “Famine” genes: enhanced by sugar depletion

Genes/enzymes (function)	Evidence: plant, tissue	Effectors tested	Refs
<i>Photosynthesis</i>			
Rubisco S-subunit [rbcS]	<i>Zea</i> protoplast, trans expr tomato lvs <i>Chenopodium</i> cell cult + tobacco and potato plants tobacco leaf protoplasts	S, acet S, G G S, G + girdl G	160, 161 194 89 89 25
Rubisco L-subunit [rbcL]	<i>Chlorogonium</i> cell cult	acet	9, 172
chl a/b-binding protein (cab, Lhcb)	<i>Zea</i> protoplasts, trans expr <i>Chenopodium</i> cell cult tobacco leaf protoplasts rape cell cult <i>Chlamydomonas</i> cults	S, G, acet, oth G G, S G acet	160, 161 89 25 55 79
atp- δ thylakoid ATPase	<i>Chenopodium</i> cell cult	G	89
malic enzyme, C4 [Me1]	<i>Zea</i> protoplasts, trans expr	S, G, acet, oth	160, 161
PEP carboxylase, C4 [Pepc1]	<i>Zea</i> protoplasts, trans expr	S, G, acet, oth	160, 161
triose-phosphate translocator	tobacco lvs	S	82
pyruvate PPdikin [Ppdk1]	<i>Zea</i> protoplasts, trans expr	S, G, acet, oth	160, 161
C4-pyruvate phosphodikinase (C4 psynth)	<i>Zea</i> protoplasts, trans expr <i>Chenopodium</i> cell cult		160, 161 70 89
<i>Remobilization</i> (starch, lipid, and protein breakdown)			
Amy3D, Amy3E α -amylase	rice cell cults	S, G, F, Mal	61, 180
α -amylase	rice, cult embryo, and scutel barley aleurone	S, G, F, endo extract Na-butyrate	74, 187, 214 94
plastid starch phosphorylase	<i>Chenopodium</i> cells, lvs	G	91
phosphoglucose mutase	<i>Chenopodium</i> cells, lvs	G	91
isocitrate lyase [Icl] (glyox cycle)	cucumber cotyledons <i>Chlorogonium</i> cells	S, G, F, 2dG, M + acet	50, 51 155
malate synth (glyox cycle)	cucumber cotyledons	S, G, F, 2dG, M	50, 51
proteases	maize root tips	G	13
asparagine synthetase (N cycling)	<i>Arabidopsis</i> shoot tissues	S	95
<i>Sucrose and mannitol metabolism</i> (synthesis and breakdown)			
acid invertase	maize root tips [<i>Ivr1</i>]	G, S, F, oth	86, 209, 210
S synth	maize root tips [<i>Sh1</i>] maize protoplasts [<i>Sh1</i>] carrot, whole plant <i>Vicia</i> seeds, cotyledons	S, G, F, oth S pruning F, G	85 104 179 57
SPS	<i>Arabidopsis</i> [<i>ASus1</i>] sugar beet rts, lvs	sink manip S	106 60
Mtol dehydrogenase	celery cell cult	S, Mtol	133

Abbreviations: 2dG, 2-deoxy-glucose; acet, acetate; cult, culture; endo, endosperm; F, fructose; G, glucose; Lhcb, light-harvesting chlorophyll-binding protein (also cab); lvs, leaves; M, mannose; Mal, maltose; Mtol, mannitol; PEP, phosphoenolpyruvate; PPdikin, phosphodikinase (cytosolic); rts, roots; scutel, scutellum; *Sh1*, *Shrunken1*; S, sucrose; SPS, sucrose phosphate synthase; trans expr, transient expression; synth, synthase.

Carbohydrate Depletion and Sugar-Responsive Genes

Plant and microbial gene responses to carbohydrate depletion have important similarities but differ as well. In both plants and microbes, sugar and acetate effects favor uptake of preferred substrates requiring the least metabolic cost and promote heterotrophic growth over photosynthesis when possible. How-

Table 2 “Feast” genes: enhanced by sugar abundance

Genes/enzymes (function)	Evidence: plant, tissue	Effectors tested	Refs
<i>Polysaccharide biosynthesis</i> (starch and other)			
AGPase [<i>Sh2</i>] (starch)	<i>Chenopodium</i> cell cult + spinach, transgenic potato lvs potato/detached lvs in dark		91 92, 116 87
starch phosphorylase	potato tuber potato/detached lvs in dark	S S	171 87
starch synth [GBSS]	potato/detached lvs in dark	S, G, F	87
branching enzyme [BE]	potato/detached lvs in dark cassava stems and lvs	S, G, F S, G, F	87 152
<i>Storage proteins</i>			
sporamin, A & B types	sweet potato/cult plts/stems sweet potato/lvs and petiole	S S, G, F	56 65, 122
β-amylase (storage protein?)	sweet potatoes and lvs sweet potatoes and lvs	S, pgal a S, G, F	122 127
patatin class I	transgenic potato promoter potato tubers and lvs transgenic potato lvs and tuber potato tuber/transgenic tobacco potato leaf and stem explants potato leaf and stem explants transgenic potato tubers	S S S S, starch S S S, Gln, dk sol. sugs.	52 36, 143 78 99 202 202 131 117
proteinase inhibitor II [Pin2]	transgenic potato tubers potato lvs/transgenic tobacco detached potato lvs transgenic tobacco	sol. sugs. S, G, F, Mal ABA, MeJA S, G, F	117 70 131 78
lipoxygenase (storage protein)	soybean <i>Lox-NR</i> soybean <i>VspB</i> soybean <i>Vsps</i>	depodding S, Mal S, G, F, MeJA	53 149 107
<i>Pigments and defense</i>			
chalcone synth (pigment/path.)	petunia in <i>Arabidopsis</i> , alfalfa protoplasts, <i>Camelia sinensis</i>	S, G, F p-coumar sugars	193 101 183
RT locus (pigment synth)	petunia/petal, anther	G + light	14
dihydroflavonol-reductase	ivy lvs and stems	sugars	120
Mn-superoxide dismutase	rubber tree/all tissues	S	110
hrp (pathology)	<i>Xanthomonas campestris</i>	S + Met	157
chaperonin 60B (protein synth)	<i>Arabidopsis</i> lvs	S	215
<i>Respiration</i>			
PGAL-dehydrog. (<i>GapC</i>) cyto	<i>Arabidopsis</i> lvs	S	211
β-isopropylmalate dehydrog.	potato, tomato, <i>Arabidopsis</i>	S, AA	66
apocytochrome 6 (<i>co6</i>)	<i>Chlorogonium</i> cell cult		93
PP-F-6-P phosphotransferase	<i>Chenopodium</i> cell cult, tobacco, and spinach lvs	G G	92 92

Table 2 (Continued)

Genes/enzymes (function)	Evidence: plant, tissue	Effectors tested	Refs
<i>Sucrose metabolism</i>			
invertase	maize root tips [<i>Ivr2</i>] <i>Chenopodium rubrum</i> carrot, whole plant	S, G, F S, G, F, 6dG manip.	87, 209 144 179
S synth	maize [<i>Sus1</i>] rice embryos <i>Vicia faba</i> cotyledons potato tubers, lvs, stems potato plants, throughout <i>Chenopodium</i> cell cults	S, G, F S, G, F S S S S, G, F	86 74 57 151 37, 38 46
SPS	sugar beet petioles transgenic potato	G sol. sugcs.	60 117
<i>Other</i>			
nitrate reductase	<i>Arabidopsis</i> lvs light/dark <i>Arabidopsis</i> plants light/dark <i>Chenopodium</i> cells/spinach lvs	S, G, F G	196 18 91
SAM synth	<i>Lolium</i> lvs	S	208
ro/C gene of Ri plamid	transgenic tobacco/phloem	S	213
30-kD Rubisco-assoc. protein	soybean lvs	pod removal	171

Abbreviations: 6dG, 6-deoxy-glucose; AA, amino acids; cult plts, cultured plants; F, fructose; G, glucose; GapC, PGAL-dehydrogenase (cytoplasmic); Gln, glutamine; Glu, glutamate; lvs, leaves; Mal, maltose; MeJA, methyl jasmonate; Met, methionine; p-coumar, p-coumaric acid; PGAL, glyceraldehyde-3-phosphate dehydrogenase; pgal a., polygalacturonic acid; PP-F-6-P phosphotransferase, pyrophosphate:fructose-6-phosphate-phosphotransferase; S, sucrose; SPS, sucrose phosphate synthase

ever, in complex plant systems, carbohydrate-regulated genes also provide a means for optimizing investment of C, N, P, etc among different plant parts and processes. Localized expression of starvation-induced genes may also aid survival of key cells and tissues under stress (84, 85).

In carbon-exporting or other autotrophic cells, photosynthetic genes are typically upregulated by sugar depletion. These include genes for the primary CO₂ fixation enzymes of both C3 and C4 plants (18, 160, 161) and other genes critical to photosynthesis (113, 160). Both nuclear (Table 1; 89) and plastid genes (25, 89, 160, 161) are affected, though the latter may respond more slowly to altered carbohydrate levels (25, 163). Enhanced expression results largely from derepression of sugar and acetate controls on transcription (89), though longevity of mRNA can also contribute to sugar modulation in vivo (162). Photosynthetic genes are repressed most by acetate (160) and often more strongly by hexoses than sucrose (69, 160, 161). Acetate effects are observed in cotyledons and in unicellular algae (Table 1; 50, 51).

The physiological consequences of sugar-induced changes in gene expression are discussed further in the section on "Implications at the Cell and Organism Level." Coordinated but often contrasting responses to sugar depletion are also evident at the enzyme level (90, 153, 175, 194). Plastid proteins

and enzymes can differ in their responses depending on whether they are encoded by nuclear or plastid genes (10, 190, 194) and whether they are involved in photosynthesis or other processes (91).

Genes for remobilization of sugars and other small molecules from polymers and/or vacuoles are also induced in exporting cells by carbohydrate depletion. In photosynthetic leaves, those genes associated with starch breakdown can be upregulated by carbohydrate depletion and repressed by glucose (91). A similar response is observed in source tissues of germinating monocot seeds, where starch hydrolysis in endosperm provides the bulk of exported sugars (61, 74, 187, 214). In addition, carbohydrate depletion in cotyledons of germinating dicot seeds upregulates genes for remobilization of lipid reserves via the glyoxylate cycle (50, 51). β -amylase genes are not enhanced by carbohydrate depletion (125, 127); however, their *in vivo* function remains unclear.

The extent of protein remobilization (and associated gene expression) can vary markedly with the degree of carbohydrate depletion (33, 68, 173). Leaf storage proteins are broken down under these conditions (53, 170, 173), though typically nonphotosynthetic cells are involved (53). Starvation effects (see below) occur only if photosynthetic capacity is severely compromised.

In carbon-importing cells, transitions to net carbon export are favored by "famine-induced" changes in gene expression. This cellular altruism in higher plants is distinct from responses of microbes and unicellular algae. Genes related to carbohydrate, lipid, and protein remobilization (Table 2 and below), amino acid synthesis (95), and sucrose formation [sucrose phosphate synthase (SPS; 60, 81)] are upregulated. Responses of SPS genes to sugar availability may be complex. In sugarbeet, a taproot-specific form of this enzyme is upregulated and downregulated by glucose and sucrose, respectively (60), whereas a spinach gene is regulated in synchrony with the sink-to-source transition (81).

Starvation and carbon conservation responses at the level of gene expression initially affect genes related to reserve remobilization (see above) and respiration (see below) that preserve structural constituents of the cell (12, 13, 68). Prolonged stress may induce genes related to breakdown, shuttling, and scavenging of cellular resources (P Ramond, unpublished data). Detoxification of nitrogenous compounds may be facilitated by upregulation of asparagine synthase (68) and sucrose synthase (Table 1). These changes are accompanied by sugar-repressible increases in activity of endoglycosidases [implicated in glycoprotein breakdown (100)], endopeptidases (49), and unidentified starvation proteins (5, 200). Under extreme starvation, the activity of enzymes involved in β -oxidation (although not a fully operative glyoxylate cycle) increases and may be associated with metabolism of membrane lipids (12, 13, 31, 68). Specific subgroups of apparently immature mitochondria and their associated proteins also disappear from starved cells under these conditions (23, 73).

Starvation stress and transport sugars can also affect accumulation of osmoprotectants. Upregulation of a mannitol dehydrogenase gene by carbohydrate depletion allows use of this sugar alcohol as a carbohydrate source (133), whereas sugar repression favors accumulation and salt tolerance (133, 185, 186). A starvation-tolerant class of genes for sucrose synthase and for invertase is also induced (85, 86); these proteins are expressed in key tissues under stress (84, 85) and at specific stages in development (209; see below).

Carbohydrate Abundance and Sugar-Responsive Genes

A large but specific set of genes is positively regulated by sugars. The majority of identified genes that are induced by elevated sugar levels encode products that help set capacity for carbon storage, utilization, and import. Other important classes include defense genes, secondary product pathways, and storage proteins.

In carbon-exporting and/or autotrophic cells, the transitions to import and storage programs are typically initiated at elevated sugar levels. The decreased expression of photosynthetic genes described above allows reallocation of the C and N (otherwise utilized in photosynthetic proteins) to other processes more advantageous under the prevailing carbohydrate environment. In this context, the concurrent upregulation of genes for nitrate reductase and a putative SAM synthase in leaves (205; Table 2) could facilitate amino acid synthesis and turnover of other N sources. Such genes may also contribute to synthesis of leaf storage proteins (Table 2; 170) and other signals including polyamines that may enhance the positive effects of sugars (180). Other aspects of gene expression related to storage and carbon use also change in *Lolium* leaves as sugar levels rise (206).

Genes related to storage reserve synthesis can be upregulated by sugars. These genes are similarly affected in both photosynthetic and nonphotosynthetic organs (84, 122, 131, 188). These changes may be associated with conversion of chloroplasts to either amyloplasts (154) or chromoplasts as sugar levels rise (64).

Genes for sucrose metabolism can be upregulated in photosynthetic tissues following manipulations that cause sugars to accumulate (151). These changes often result in elevated starch levels (167, 168) especially in cells alongside major veins (124).

In carbon-importing cells, genes for starch biosynthesis have received the greatest attention. Those encoding ADPG-pyrophosphorylase (AGPase), a key step in starch biosynthesis, are markedly sugar responsive in potato (87, 89, 116). AGPase expression is also strongly enhanced by sugars in transgenic potato cell cultures (116) and in other species (175). Corresponding increases in activity of the AGPase enzyme are not necessarily observed but may occur

more slowly (175). Starch synthase and branching enzyme are also induced and/or expressed at elevated levels when sugars are plentiful (87, 152). Carbohydrate regulation of sucrose synthase genes is complex and not necessarily directly related to starch synthesis. The *Shrunken1* (*Sh1*) gene for sucrose synthase in maize can directly affect synthesis of starch and/or cell wall materials (20, 123, 124); however, a second gene, *Sus1*, responds more strongly to elevated sugars (85; see section on Contrasting Response Classes Among Genes for Sucrose Metabolism).

Genes encoding storage proteins were among the first sugar-responsive genes identified. A gene for sporamin storage protein in sweet potatoes (56) is upregulated in situ, and it is ectopically expressed in plantlets treated with high sugars. The patatin storage protein genes of potato also respond positively to high sugar levels (78, 99, 131, 202). An additional group of sugar-modulated genes includes vegetative storage proteins, which are expressed at elevated sugar levels in several species (29, 107, 149). Many of these proteins have enzyme activity in addition to a storage function. The *Vsp* gene groups A and B of tobacco encode proteins with phosphatase activity (149); a soybean vegetative storage protein has lipoxygenase activity (53); the patatins are lipid acyl hydrolases (52, 202); and the WIN and Pin-II storage protein genes of *Solanum* spp. are proteinase inhibitors (70). Studies of sugar responsiveness in these genes have revealed important interactions between carbohydrate supply and other signals (e.g. N, P, auxin, etc).

A number of pigment and defense genes are positively modulated by carbohydrates (77; Table 2). The products of these genes mediate plant interactions with other organisms, either as pathogens, pollinators, or fruit dispersal agents. Often these interactions involve enhanced carbon use by the plant; however, effects on biosynthesis of pigments, proteins, and chaperonins can be distinct.

Respiratory genes are affected to varying degrees by sugars (Table 2). Both nuclear- and plastid-encoded genes can show positive responses, with the latter upregulated through both mRNA abundance and gene copy number (93). Mitochondrial ubiquinone mRNA is also strongly affected (B Collins, P Raymond, R Brouquisse, CJ Pollock & JF Farrar, unpublished data), as are levels of cytochrome oxidase and activity of fumarase (91). As in yeast, however, carbohydrates do not globally upregulate respiratory genes. For example, mRNA levels may remain constant for glycolytic genes [often used as controls (89, 92)] even though other respiratory genes respond to elevated glucose levels (91, 92; see Table 2).

Genes for sucrose metabolism can be strongly affected by high sugar levels in importing as well as exporting cells. The complex carbohydrate regulation of the invertases and sucrose synthase genes that control the two known paths for sucrose breakdown is discussed in the following section.

Contrasting Response Classes Among Genes for Sucrose Metabolism

Genes for sucrose metabolism occupy a central position not only in carbon flow but also in the production of alternate potential effectors of the sugar-sensing system. This altered expression of genes in sucrose metabolism could affect whole-plant adjustment to changes in carbohydrate supplies at several levels. Shifts in resource allocation are often directly correlated with activity of the respective enzymes, and indirect effects on signaling systems could further amplify changes in expression of these genes as well as genes affecting developmental programs. Collectively, these changes could also lead to changes in plant form that fine-tune acclimation.

Sucrose metabolism is the first step in carbon use by the majority of importing cells in plants (21, 115, 181). Two recently appreciated features of sucrose metabolism are particularly interesting. First, the genes for invertase as well as sucrose synthase are sugar-modulated (84, 144, 179, 209). Second, isozyme forms of each enzyme show contrasting carbohydrate responses (84, 85, 209). (In each instance, one isozyme is upregulated while one or more others are repressed.) Sugar-modulation of genes for both known paths for sucrose metabolism provides a potential mechanism for coarse control of this process.

The presence of isozyme forms with contrasting carbohydrate responsiveness was an unexpected finding. Reciprocal expression was first observed for sucrose synthases (85) and subsequently for invertases (209, 210). Initial studies of sugar-modulated gene expression were perplexing because of contradictory results. Sucrose synthase was reportedly both repressed (83, 104, 169) and enhanced in the presence of abundant carbohydrate supplies (74, 151). The reciprocal sugar responsiveness of genes encoding distinct isozymes is likely to have been responsible (85). Differentially responsive genes could also explain the contrasting effects of light on expression of sucrose synthases of wheat (105).

The surprising similarity between differential sugar-modulation of different genes for invertases (209, 210) and sucrose synthases in maize indicates that there are two sugar-response classes among genes for sucrose metabolism. Both the *Sh1* gene for sucrose synthase and the *Ivr1* gene for invertase (210) are expressed maximally when supplies of metabolizable sugars are limited [e.g. ca 10 mM glucose (0.2% w/v)] (85, 209). Both types of mRNA persist during carbohydrate starvation stress in root tips, and they are enhanced at key sites and times during reproductive development (84, 85, 209, 210). In contrast, the *Sus1* gene for sucrose synthase and the *Ivr2* gene for invertase both respond positively to abundant carbohydrate supplies [e.g. ca 100 mM glucose (2.0% w/v)] and are expressed in a broad range of importing tissues (209, 210). A “feast”-responsive set of isozymes for both paths of sucrose breakdown could

aid adjustment of import and metabolism relative to photosynthate availability. The potential value of up- or downregulating sucrose utilization in balance with its supply is consistent with the broad distribution of this isozyme form among importing tissues. In contrast, the potential physiological significance is less clear for the isozyme genes expressed when carbohydrate supplies are limited. To date, little is known about differences between properties of the invertase isozymes, although the sucrose synthases appear to be enzymatically similar (32). It is possible that more recent work showing phosphorylation of this enzyme (63, 86, 159) may be related to differences in properties of the sucrose synthase isoforms (63).

Additional clues to the biological importance of sucrose synthase and invertase isozymes whose genes are upregulated under “famine” conditions may lie in the altered protein localization and reproductive timing of expression. Under starvation stress, sucrose synthase protein in maize root tips is localized to epidermis and vascular strands while being markedly depleted from the cortex (56a, 85). Cortical cells are often sacrificed during various stresses, including low oxygen, N, or P availability (56a, 84, 108), whereas vascular and epidermal tissues are preserved. Living epidermis appears to be essential for nutrient and water uptake in many species and is very often associated with a hypodermis (having endodermal-like functions) and a rhizosheath of soil particles bound to the root surface by polysaccharide secretions [also sugar modulated in their extent (114)] (132, 108). It is possible that import priority could be conferred on essential cells and tissues during periods of limited resources by localized upregulation of special isoforms of sucrose metabolizing enzymes (84, 85). This would be consistent with upregulation of the same starvation-tolerant isoforms in specific reproductive tissues and in their additional localization in apices of roots and shoots preserved at the expense of other tissues in a starving plant (6). Our current knowledge of the *Sh1* sucrose synthase and *Ivr1* invertases of maize is consistent with this hypothesis (86, 209).

IMPLICATIONS AT THE CELL AND ORGANISM LEVEL

Long-Term Metabolic Changes

The relatively slow kinetics of the carbohydrate-induced changes in gene expression (85, 175) and enzyme activity (84, 86) are consistent with the time frame often required for source/sink adjustments at the whole-plant level (41). The physiological changes parallel the altered expression patterns of individual genes. Photosynthesis and C-conservation are generally enhanced when sugar supplies are limited, and utilization usually predominates when sugars are abundant.

Changes in photosynthetic processes resulting from sugar-modulated gene expression generally occur over an extended time period (ca 3–7 days) (84,

86, 175) and may amplify shorter-term effects of direct metabolic control (35, 62). Altered transcript abundance can occur within a few hours or less in some systems (144, 161), although initial changes are often not evident until ca 12–24 h and progress slowly thereafter. Consistent with this time scale, early work by Geiger (41) showed that changes in photosynthetic capacity in response to altered source-sink balance takes 3–4 days. Also, as plants acclimate to elevated CO₂, photosynthetic rates decline over a period of days after an initial increase (27), possibly because of the repressive effects of accumulated sugars in leaves (194).

Invertase activity in leaves may indirectly affect repression of photosynthetic genes by accumulated sugars because hexoses may affect the sugar-sensing system more directly than sucrose (69, 160, 161; see section on Carbohydrate-Sensing Systems). Hexoses in particular have been implicated in long-term repression of photosynthetic genes (59, 175). Species with high levels of leaf invertase show a greater degree of photosynthetic inhibition in instances of reduced sucrose export (47). This effect is substantiated in transgenic invertase overexpressors (30, 58, 166, 168, 177, 198), where sucrose export from mature leaves is inhibited and hexose production enhanced. Pollock et al (136) also found that elevated leaf sucrose had little inhibitory effect on photosynthesis while fructans were being actively synthesized and stored in vacuoles (presumably removing hexoses from the cytosol). Long-term influences of hexoses on photosynthesis are likely to involve other factors as well (35, 42, 62, 176). Krapp et al (89) suggested that, as in yeast, hexose metabolism may be required for repressive effects of sugars on gene expression; they found an imperfect correlation between hexose levels and photosynthetic repression.

Leaf senescence may also be enhanced by long-term hexose effects on gene expression. In this context it is interesting that invertase activity is elevated during aging (135). Hexoses in particular may favor expression of genes involved in remobilization of photosynthetic machinery and altered pigment synthesis (Tables 1 and 2). Acetate effects are still more pronounced (160), which indicates that lipid breakdown and mobilization may accelerate senescence. The putative advantage of sugar repression of photosynthetic genes is that valuable resources need not be committed to this process if carbohydrate supplies are already sufficient.

Pigment changes and chloroplast-to-chromoplast conversions during fruit ripening and senescence may be affected by carbohydrate-sensitive genes (201). In ivy, sugar-sensitive gene expression has been directly related to induction of enzyme activity leading to pigment accumulation (119, 120). In citrus peel, sugars mediate interconversions between chloroplasts and chromoplasts (64). Regreening occurs in late-ripening oranges as peel sugar levels drop in spring. Rising sugar levels are consistently associated with the chloroplast-to-chromoplast conversion in autumn. Sugars can also stimulate these changes in

chlorophyll, carotenoid, and plastid characters *in vitro* (48). Chloroplast-to-chromoplast conversions are also enhanced by the induction of invertase at low temperature in citrus (138). Many of the nuclear-encoded plastid genes are also readily responsive to sugar levels (Tables 1 and 2), whereas chloroplast genes appear to be less so (194). As noted above, however, the responsiveness of chloroplast genes to acetate suggests that this metabolite could be important in plastid conversions.

Changes in storage processes are closely related to carbohydrate-responsive gene expression. Sugar effects on storage organ formation are discussed below (see section on Interaction with Developmental and Environmental Signals). In addition, most instances of enhanced gene expression cited in Table 2 are accompanied by respective increases in enzyme activity and storage of carbohydrate and/or proteins (e.g. 146, 197). Further, sugar effects on an α -amylase gene family and on sucrose synthase correlate with the balance between endosperm remobilization and the demands of the growing seedling (188).

Respiratory changes related to sugar-modulated gene expression are less clear. The hypothesis for “coarse control” described by Farrar & Williams (34) indicates that long-term respiratory responses follow extended changes in carbohydrate availability and probably require altered gene expression. Although evidence supports this view, the relationship between carbohydrates and gene expression is complex, and aspects of the story remain unresolved. Respiration typically rises in response to increasing levels of sugars (8, 34, 96, 109), and it decreases with starvation (12, 68, 140)—as do expression levels of many genes related to respiratory processes (Table 2). Concurrent increases in levels of key mRNAs and of associated respiratory activity have been observed as sugar content rises in maturing leaves of transgenic plants overexpressing invertase (175). Similar correlations have been made in several species (89, 93). Kroymann et al (93) suggested coordination through a signal related to cellular energy charge. The ATP/ADP ratio rises along with respiration and associated transcript levels (89). However, the evidence gathered thus far does not necessarily support adenylate charge as a direct signal for carbohydrate-responsive genes (175, 161; see section on Key Metabolites as Direct Signals). Other issues not yet fully resolved include the role of changes in organelle number (140) and genome copy number (93), the importance of the alternate oxidase (96), significance of Pi and adenylates to gene expression (161, 175), and the potential impact of acetate on the carbohydrate signaling.

Carbohydrate-Responsive Genes, Assimilate Partitioning, and Development

The ultimate significance of sugar-modulated gene expression may be induction of changes in whole-plant morphology. Taken together, the trends in gene expression, subsequent metabolic changes, and shifts in resource allocation

are consistent with this suggestion. Sugar modulation of developmental genes is implied by responses such as potato tuber induction (165); however, the specific genes involved have not been identified. The pronounced interactions between carbohydrate levels and plant growth regulators (especially auxin/sugar antagonisms) and other essential nutrients such as N or P suggest that sugars may affect development at the cell, organ, and whole-plant levels. The type of carbohydrate supplied to cells and callus cultures can also affect morphological change not attributable to osmotic effects.

Figure 1 summarizes the developmental trends implied by the gene expression changes known to occur in carbon-importing and -exporting tissues under feast and famine conditions (see Figure 1). A number of studies support the notion that C-availability can affect C-allocation through altered gene expression (see discussion on partition in section on Contrasting Response Classes Among Genes for Sucrose Metabolism). This in turn can affect partitioning between root and shoot structures (43, 134, 167, 179, 204). Other seemingly contradictory results obtained when different methods are used to manipulate sugar availability might also be interpreted within this simplified framework. Both root and shoot growth are inhibited in transgenic plants with excess invertase, presumably because translocation to the root system is disrupted (175) and high hexose levels simultaneously repress photosynthetic genes in leaves. In contrast, shoot growth may be indirectly enhanced when sugars are supplied to whole plants via the root system (56, 88), if increased root growth leads to increased capacity for cytokinin synthesis, which in turn may stimulate shoot growth and photosynthetic processes (112).

Carbohydrate-induced changes in vegetative morphology often involve an altered balance of growth regulators and mineral nutrients (130, 207). Sugars can repress auxin-mediated processes including apical dominance and upright stem growth (negative geotropism) resulting in more spreading, procumbent growth forms (203). Expression of genes now known to be sugar responsive may also have a role in gravitropism (75, 76). In addition, sugar induction of storage organs in potato and sweet potato can be distinguished from regulation of the genes associated with storage processes per se. Although some of the latter processes are coordinately regulated (197), the morphological program remains separately sugar responsive (117).

Cell differentiation and the cell cycle can also be strongly affected by sugar availability. Development of tracheid vs phloem cells can be controlled by sugar/auxin balance (39), and other effects of specific sugars on differentiation have been reevaluated in cultured cells (191). The cell cycle within a given tissue can be synchronized by withholding and resupplying sugars (200). In addition, cell divisions can be induced in nongrowing buds of sunflower by elevated sugar levels (2).

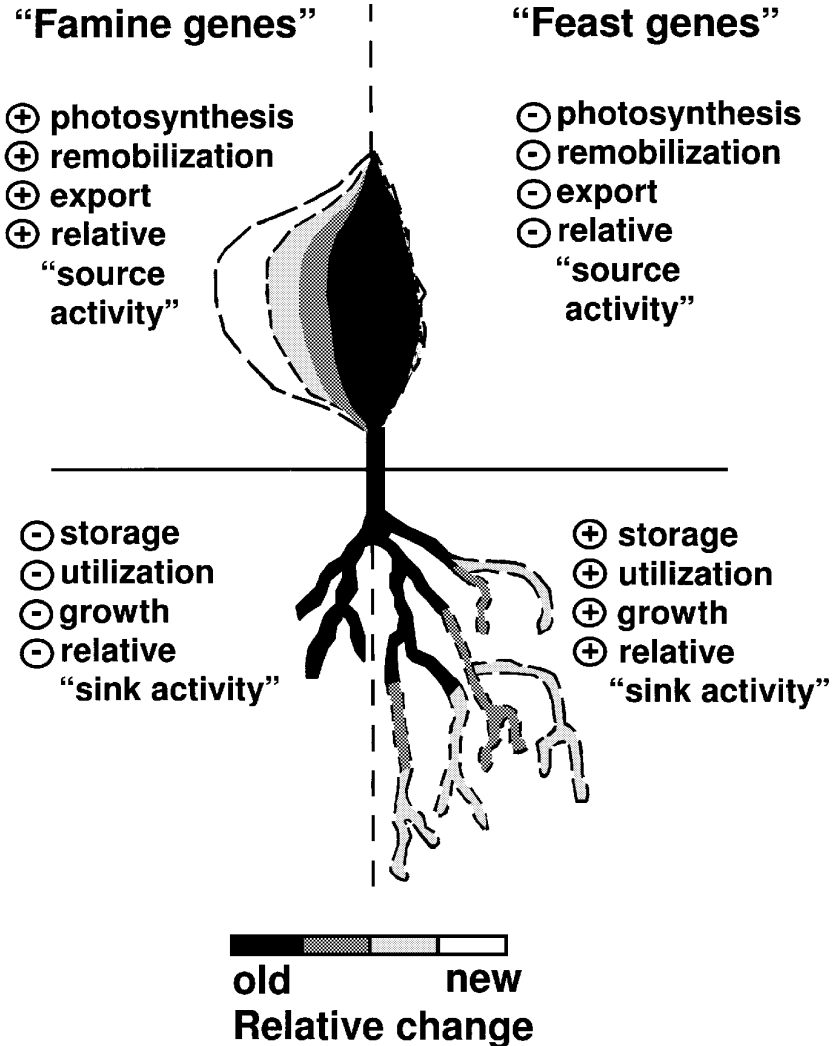

Figure 1 The impact of sugar-modulated gene expression on overall activity and resource allocation is diagrammed figuratively at the whole-plant level (changes do not necessarily represent actual morphological changes per se). “Feast” and “Famine” genes are those upregulated and downregulated under conditions of limited and abundant carbohydrate supplies, respectively, in either exporting (upper half) or importing tissues (lower half). Processes favored by these changes in gene expression are designated with a (+), and processes that are diminished are designated with a (-).

Sugar-induced changes to reproductive programs may be closely related to effects on the cell cycle. Sugar pulses to apical meristems can initiate synchronous cell divisions that precede other aspects of floral meristem differentiation (7, 97). High levels of apical sugars can also amplify photoperiod effects on floral evocation in *Lolium temulentum* and replace it fully in *Sinapis alba* (80, 137). In the latter case, concomitant with increased apical sugar levels, increases in invertase are observed in the apical meristem (137). Some invertase genes are sugar-regulated (84, 144, 210) and have the potential to enhance sugar perception by hexose sensing systems (see below). In addition, sugars supplied through roots can suppress phenotypes of early- and late-flowering mutants in dark-grown *Arabidopsis* plants (J Salinas, personal communication).

Interactions with Developmental and Environmental Signals

Effects of carbohydrate availability on fruit and seed set may mediate responses to certain environmental stresses. Studies of stress-induced kernel abortion in maize show that exogenous carbohydrate supply (11) and short-term reserves in young ovules (141) are crucial to kernel set in conditions of low water (216) or high temperature stress (17). Sugar-feeding studies have implicated the final phase of import and use of these substrates within the developing ovule as critical (11, 17; J Boyer, unpublished data). Effective sugar utilization in vivo is strongly dependent on the activity of sucrose metabolizing enzymes (21, 111, 115, 181) that are encoded by sugar-responsive genes (Tables 1 and 2; 85, 209). Soluble invertase occupies a conspicuous position during the earliest phases of fruit and seed set (181, 209), and that activity is selectively affected by abortion-inducing stresses such as low water potential (216). Although the evidence is thus far largely correlative, the sugar responsiveness of soluble invertase genes could provide a mechanism for integrating and transducing information on the C-resources available to the fertilized ovule.

Developmental signals mediated by growth regulators can have marked effects on carbohydrate-modulated genes. The nature of this interface is still poorly defined. However, work by Mullet and coworkers (29) indicates that one of two different sugar-responsive promoters they studied is sensitive to auxin/sugar antagonism. Similar response elements could explain the repression of sugar responses (179) by auxin analogs in cell cultures (178) and auxin modification of sugar effects on invertase expression at the whole-plant level (45, 148, 203). Gibberellin interaction with sugar signaling is apparent in germinating grain seeds (187, 188) and stolen starch metabolism (4). Cytokinin and sugar signals overlap in transcriptional regulation of nitrate reductase (18, 196), invertase (209), and other genes (26). They can also affect respiration

(121), the cell cycle (67, 98), auxin antagonism (112), kernel abortion (17, 71), and an array of morphological changes (112).

Interactions between environmental signals and sugar-responsive genes do not necessarily involve developmental programs. Elevated sugar supply, osmotic stress, and pathogen invasion all upregulate the *mtd* gene for mannitol metabolism and enhance synthesis of this osmotic protectant (133). Mannitol in turn imparts enhanced salt tolerance in transgenic plants (184, 185). Osmotic adjustment can also be affected by sugar-regulation of invertases (212), which could in turn sensitize cells to sugar supplies by the elevation of hexoses (161, 177). Similar to *mtd* and some other sugar-responsive genes (70), invertase is induced by wounding (178).

Recent progress has also been made in defining the interface between sugar-sensing systems and the transduction of various light signals (19). Sheen pointed out (161) that the carbohydrate-repression of photosynthetic genes supersedes many of the light effects. Chory (19) proposed that light signals are partly filtered through a sugar-regulated segment of the transduction pathway. Parks & Hangarter (128) also found that blue light effects can differ depending on tissue sugar status. The effects of sugars on photoperiodic responses were discussed above. In addition, high irradiance responses (HIR) such as anthocyanin biosynthesis in fruit skins overlap sugar effects.

Influence of essential mineral nutrients such as N (24) and P (186) on gene expression and morphology is often strongly linked to carbohydrate status (130). Several possible avenues for C/N interactions or P effects on C-signaling have thus far tested negative (175). Sadka et al (149), however, found that P availability altered sugar-regulated transcription of a carbohydrate-sensitive promoter element.

CARBOHYDRATE-SENSING SYSTEMS

Several lines of evidence indicate that sugar effects on gene expression involve specific signaling mechanisms and do not simply result from their nonspecific effects as substrates for plant growth. First, the effects of sugars on gene expression are highly selective; many genes are not affected. Second, sugars can repress as well as activate responsive genes. Third, in many cases, sugar-modulated gene expression can be mimicked by nonmetabolizable sugar analogs (69, 160, 161) and altered by selective metabolic perturbations (102, 161, 175, 182). Finally, sugars are well-known effectors of gene expression in microbes.

Microbial sugar-sensing mechanisms are an important resource for development of testable hypotheses in plants (50, 51, 69, 160). However, the emerging picture of sugar signaling in plants highlights important differences (40, 150, 192) and intriguing similarities with microbes.

Hexose Phosphorylation and Protein Kinase Cascades

An important hypothesis for sugar sensing stems from the evidence that phosphorylation of hexoses by hexokinase is a well-documented primary source of sugar signaling in yeast (161). The hexokinase itself is proposed to have a dual function as a protein kinase (40) sensitive to the flux of sugars entering metabolism. Because the rate of hexose phosphorylation is more important than the steady-state level of hexose-P produced in yeast, the concentration of hexokinase enzyme-product complex is proposed to be directly involved in signaling carbon flux through the pathway.

As in yeast, sugar concentrations per se are not necessarily correlated with changes in plant gene expression. Analysis of maize mutants with high-sugar kernels (44) and transgenic, sugar-storing potatoes (117) showed little or no change in expression of genes otherwise affected by sugars. Although compartmentalization of sugars was not addressed in these studies, the results may be interpreted as evidence that carbon flux rather than steady-state sugar level is the critical signal. The data that support a corresponding role for hexokinases in plants center largely on responses to sugars (2-deoxyglucose and mannose) that are rapidly phosphorylated by hexokinases but that do not readily undergo subsequent metabolism. Positive responses to these sugars have now been observed in several plants (50, 51, 69, 160, 161, 175). In at least one study, the effects of nonmetabolizable sugars were shown to be blocked by addition of mannoheptulose, an inhibitor of hexokinase (69). By analogy to yeast, these results are interpreted as favoring flux through the hexokinase reaction as the inductive signal (50, 51, 69, 160). Other associated perturbations have not been fully excluded, although changes in Pi levels appear to have little effect (175).

If the hexokinase hypothesis remains viable in plants, the wide variation in specificity of plant hexokinases for glucose as opposed to fructose (156) may add a fascinating layer of complexity to the regulatory scenario in plants. Recent data from yeast indicate that glucokinases do not have the same sugar-sensing impact as the hexokinases (145).

Extensive studies in yeast have also identified downstream components of a protein kinase cascade involved in transmitting signals to the nucleus (40). Putative homologs of the yeast *snf1* gene have been identified in rye (RKIN1) (1), tobacco (NPK5) (3, 118), and barley (a multigene family) (54). Nakamura and coworkers have shown that calcium levels (125) and a calcium-dependent protein kinase (CDPK) (126) may be involved in sugar induction of sporamin and β -amylase genes in transgenic tobacco. The latter finding suggests that sugar sensing in plants may be distinct from mechanisms in other systems because CDPKs appear to be lacking in other organisms (142). The localization of this CDPK on the plasmamembrane of plant cells suggest

a possible association with the sites of membrane transfer. Other recently isolated plant genes are similar to the glucose-regulated proteins (GRP) involved in secretion and ER function in mammals (28, 164). Putative sugar-sensing-related DNA binding proteins have been isolated from several plants (65, 78, 103), but as yet they have no clear relationship to components of signal transduction pathways in other organisms. The functions of these genes are under study.

Plasmamembrane Transfer

In microbes, transfer of sugars across the cell membrane is critical for sugar sensing and may be closely coupled to hexokinase action (150). In plants, the role of membrane transport has been tested using sugar analogs that are nonmetabolizable and nonphosphorylatable (as distinct from the analogs used to implicate hexokinases) but actively taken up by plant cells. Data from W Frommer (unpublished) and Roitsch et al (144) suggest that transfer across the plasmamembrane alone (or the configuration of the sugar analog per se) can initiate a signal. The studies of Jang & Sheen (69) indicate that transfer across the membrane was necessary but not sufficient to initiate a response. In plants, a direct involvement of membrane transport has the added implication that sugars entering the cell via plasmodesmata (symplastic transfer) might be perceived differently from sugars taken up from the apoplast (see Figure 2).

Depending on the tissue, sugars may enter a plant cell via any of three routes: (a) through plasmodesmata (symplastic transfer), (b) across the plasmamembrane as sucrose (from the apoplast), and/or (c) across the plasmamembrane as hexoses (again from the apoplast). As illustrated in Figure 2, each path has the potential to transmit different signals to a sugar-sensing mechanism. If plasmamembrane transfer is directly involved in signaling, then hexose uptake from the apoplast would potentially exert a greater effect per unit C than sucrose. Sucrose arriving via plasmodesmatal connections would not exert a similar membrane signal, although plasmodesmata might have an as yet undefined role in sugar sensing. Preliminary evidence indicates that altered photosynthate availability may affect size exclusion limits in plasmodesmata and promote pathway switching (i.e. extent of apoplastic vs symplastic transfer) (129, 147).

The alternative pathways by which sugars enter cellular metabolism may also impact sugar-sensing mechanisms (Figure 3). Hydrolysis of sucrose by invertase generates twice as much substrate for a hexokinase-based sensor as does sucrose synthase. Sucrose synthase, on the other hand, generates UDPG, which may feed into other signaling pathways. Vacuolar compartmentalization and hydrolysis by invertase may affect the timing of hexose-signaling events.

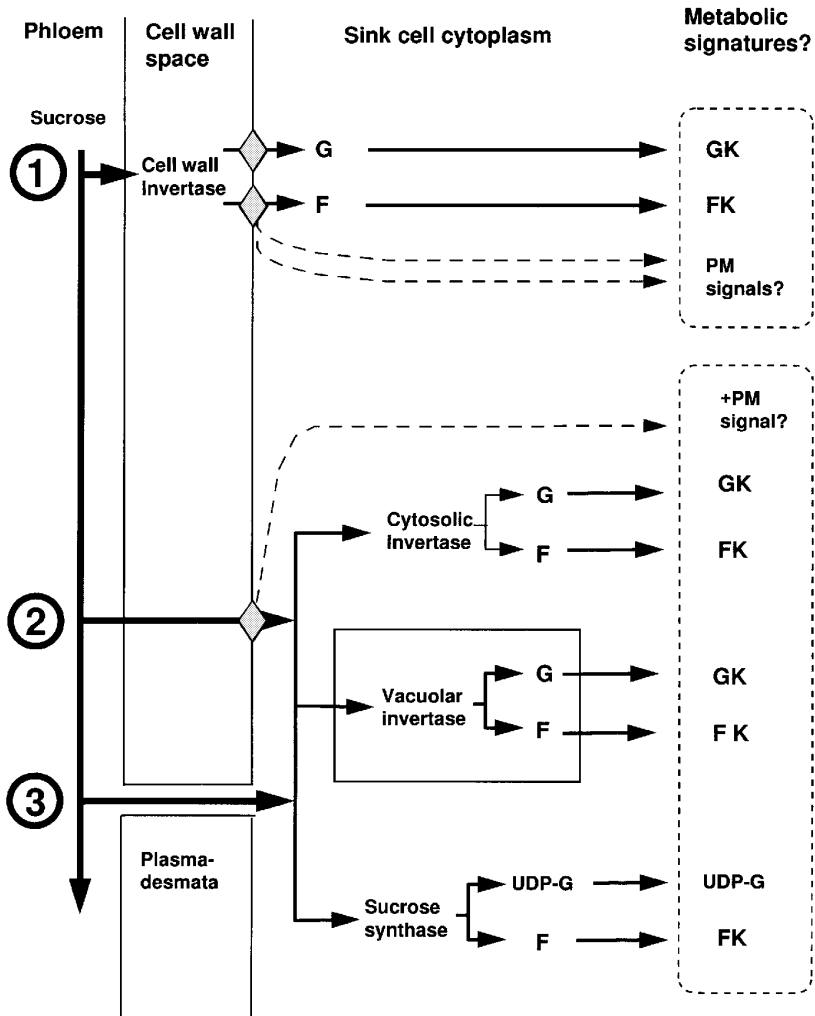
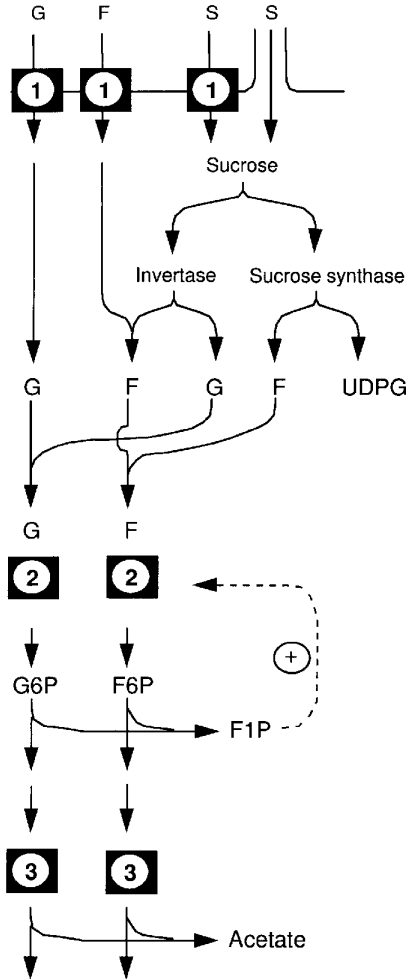

Figure 2 Potential differences in metabolic signatures of sugars entering plant cells and their relevance to the carbohydrate-sensing system. Three different physical paths of sucrose import are shown, with potential signals from plasmodesmata identified with diamonds and dashed lines. Within importing cells, potential input into the hexokinase aspect of the signaling system is designated by FK or GK. Differences in possible metabolic signatures depending on the entry path and initial sucrose cleavage reaction are shown in dashed boxes at the far right.

Carbon Flow:



*** Effectors of gene expression**

1 Plasmamembrane Signal?
(Plasmodesmata?)

2 Hexokinase Signal?
(UDPG?)

3 Acetate Signal?

Figure 3 Potential points of signal input into the carbohydrate-sensing system of plants. A simplified path of C-flow is shown at the left with corresponding sites of signal input at the right.

Key Metabolites as Direct Signals

A second source of hypotheses for sugar signaling has come from analogies to pathways for regulation of metabolism (175). The possibility that the same metabolites could mediate regulation of both metabolism and genes in these pathways would provide an attractive mechanism for coordinating rapid metabolic changes with longer-term adjustments in gene expression (34, 134, 175). However, key metabolites such as F-2,6-BP, sugar-P, adenylates, and the Pi/PPi ratio, which collectively regulate carbohydrate metabolism, appear to have little or no direct involvement in sugar regulation of gene expression in the systems studied thus far (161, 175). Levels of F-2,6-BP have been altered using inhibitors and in transgenic plants expressing an antisense gene for PPI-dependent phosphofructokinase without affecting carbohydrate-responsive genes (175; A Krapp and M Stitt, unpublished data). Likewise, various manipulations of Pi levels altered metabolism in predictable ways but did not change expression of sugar-modulated genes (175). Introduction of various phosphorylated sugars, adenylated sugars, and ATP into cells by electroporation failed to affect sugar-responsive genes (161).

Although sugar levels can vary widely in plants, maintenance of “energy homeostasis” is one proposed function of carbohydrate-regulated gene expression (69). The search for a link between respiratory metabolism and gene expression continues. One possible link to a mitochondrial function involves its role as a calcium reservoir sensitive to changes in respiratory substrates (72). Changes in redox potential are also a possibility, as observed for chloroplast mRNAs (28a). Adenylate balance may also be involved through an influence on a hexokinase-based sensing mechanism. In this respect, it seems not widely appreciated that the concentration of enzyme-product complex will be directly proportional to the net forward flux through the reaction only under initial velocity conditions, and these conditions are not likely to apply *in vivo*. Nearer to equilibrium, the intermediate enzyme complexes will be affected by concentrations of all substrates and products including hexose, hexose-P, ADP, and ATP. It might be more accurate to view yeast hexokinase as a sensor of some ratio of these metabolites rather than flux *per se*.

The profound effects of acetate on yeast and algal cultures are well known (9, 93, 172), yet the significance of this metabolite to higher plants has been explored only recently in leaf protoplasts (160) and intact cotyledons (50, 51). Acetate appears to be the strongest input into the carbohydrate-sensing system of maize leaf protoplasts (160). It is not clear whether there are points of overlap between this signal and sugar inputs. Signal initiation from these two metabolites appears to occur differently. In this context, it is also intriguing that lipid acyl hydrolases have been recruited as carbohydrate-responsive storage proteins in potato (52, 202).

CLOSING COMMENTS

In multicellular organisms, carbohydrate-responsive gene expression acquires a functional significance beyond that observed in microorganisms. As in yeast and bacteria, specific groups of genes show dramatically different responses to changes in the carbohydrate environment and include both up- and downregulation of gene expression. In multicellular structures, however, individual cells respond to changes in the internal carbohydrate environment of the organism, thus allowing coordinated long-term adjustments for the benefit of the whole.

Plants in particular appear to have successfully employed this mechanism for meeting the adaptive demands of their sessile existence. The sites, timing, and extent of sugar-modulated gene expression described here indicate that these processes may contribute to the dynamic allocation of carbon resources and the continuous adaptive adjustment of form so characteristic of multicellular plants. Sugars in vascular plants are thus long-distance messengers of whole-organism carbohydrate status as well as substrates for both cellular metabolism and local carbohydrate-sensing systems. Although the primary source of carbohydrate signals is currently unclear, hexokinase action and acetate levels remain a common theme shared by mammalian and microorganism sensing systems. The pathways for transduction of sugar signals overlap with other environmental and developmental signals affecting gene expression.

ACKNOWLEDGMENTS

Sincere appreciation is extended to Tami Spurlin, Thea Edwards, Wayne Avigne, and Kalavathy Padmanabhan for their invaluable help in compilation of the work presented here. Research contributions from the author's laboratory were made possible by funding through the National Science Foundation, the USDA-NRI, and Florida Agricultural Experiment Station. This paper is Journal Series No. R-04999

**Any Annual Review chapter, as well as any article cited in an Annual Review chapter, may be purchased from the Annual Reviews Preprints and Reprints service.
1-800-347-8007; 415-259-5017; email: arpr@class.org**

Literature Cited

1. Alderson A, Sabelli PA, Dickinson JR, Cole D, Richardson M, et al. 1991. Complementation of *snf1*, a mutation affecting global regulation of carbon metabolism in yeast, by a plant protein kinase cDNA. *Proc. Natl. Acad. Sci. USA* 88:8602-5
2. Ballard LAT, Wildman SG. 1963. Induction of mitosis by sucrose in excised and attached dormant buds of sunflower (*Helianthus annuus* L.). *Aust. J. Biol. Sci.* 17:36-43
3. Banno H, Muranaka T, Ito Y, Moribe T, Usami S, et al. 1993. Isolation and

- characterization of cDNA clones that encode protein kinases of *Nicotiana tabacum*. *J. Plant Res.* 3:181–92
4. Baur-Höch B, Mächler F, Nösberger J. 1990. Effect of carbohydrate demand on the remobilization of starch in stolons and roots of white clover (*Trifolium repens* L.) after defoliation. *J. Exp. Bot.* 41:573–78
 5. Baysdorfer C, Van Der Woude WJ. 1988. Carbohydrate responsive proteins in the roots of *Pennisetum americanum*. *Plant Physiol.* 87:566–70
 6. Baysdorfer C, Warmbrodt RD, Van Der Woude WJ. 1988. Mechanisms of starvation tolerance in pearl millet. *Plant Physiol.* 88:1381–87
 7. Bernier G, Havelange A, Houssa C, Petitjean A, Lejeune P. 1993. Physiological signals that induce flowering. *Plant Cell* 5:1147–55
 8. Bingham IJ, Stevenson EA. 1993. Control of root growth: effects of carbohydrates on the extension, branching and rate of respiration of different fractions of wheat roots. *Physiol. Plant.* 88:149–58
 9. Böege F, Westhoff P, Zimmerman K, Zetsche K. 1981. Regulation of the synthesis of ribulose-1,5-bisphosphate carboxylase and its subunits in the flagellate *Chlorogonium elongatum*: the effect of light and acetate on the synthesis and the degradation of the enzyme. *Eur. J. Biochem.* 113:581–86
 10. Börner T, Hess WR. 1993. Altered nuclear, mitochondrial and plastid gene expression in white barley cells containing ribosome-deficient plastids. In *Plant Mitochondria*, ed. A Brennicke, U Kück, pp. 207–20. New York: VCH Publishers Inc.
 11. Boyle MG, Boyer JS, Morgan PW. 1991. Stem infusion of liquid culture medium prevents reproductive failure of maize at low water potential. *Crop Sci.* 31:1246–52
 12. Brouquisse R, James F, Pradet A, Raymond P. 1992. Asparagine metabolism and nitrogen distribution during protein degradation in sugar-starved maize root tips. *Planta* 188:384–95
 13. Brouquisse R, James F, Raymond P, Pradet A. 1991. Study of glucose starvation in excised maize root tips. *Plant Physiol.* 96:619–26
 14. Brugliera F, Holton TA, Stevenson TW, Farcy E, Lu CY, Cornish EC. 1994. Isolation and characterization of a cDNA clone corresponding to the *Rt* locus of *Petunia hybrida*. *Plant J.* 5:81–92
 15. Carlson M. 1987. Regulation of sugar utilization in *Saccharomyces* species. *J. Bacteriol.* 169:4873–77
 16. Cheikh N, Jones RJ. 1994. Disruption of maize kernel growth and development by heat stress: role of cytokinin/abscisic acid balance. *Plant Physiol.* 106:45–51
 17. Cheikh N, Jones RJ. 1995. Heat stress effects on sink activity of developing maize kernels grown in vitro. *Physiol. Plant.* 94:59–66
 18. Cheng CL, Acedo GN, Crustinsin M, Conkling MA. 1992. Sucrose mimics the light induction of *Arabidopsis* nitrate reductase gene transcription. *Proc. Natl. Acad. Sci. USA* 89:1861–64
 19. Chory J. 1993. Out of darkness: mutants reveal pathways controlling light-regulated development in plants. *Trends Genet.* 9:167–72
 20. Chourey PS, Nelson OE. 1976. The enzymatic deficiency conditioned by the *shrunken-1* mutations in maize. *Biochem. Genet.* 14:1041–55
 - 20a. He C-J, Drew ME, Morgan P. 1994. Induction of enzymes associated with lysigenous aerenchyma formation in roots of *Zea mays* during hypoxia or nitrogen starvation. *Plant Physiol.* 105:861–65
 21. Claussen W. 1983. Investigations on the relationship between the distribution of assimilates and sucrose synthetase activity in *Solanum melongena* L. II. Distribution of assimilates and sucrose synthetase activity. *Z. Pflanzen Physiol.* 110:175–82
 22. Claussen W, Hawker JS, Loveys BR. 1985. Sucrose synthase activity, invertase activity, net photosynthetic rates and carbohydrate content of detached leaves of eggplants as affected by attached stems and shoots (sinks). *Plant Physiol.* 119:123–31
 23. Couée I, Murielle J, Carde JP, Brouquisse R, Raymond P, Pradet A. 1992. Effects of glucose starvation on mitochondrial subpopulations in the meristematic and submeristematic regions of maize root. *Plant Physiol.* 100:1891–900
 24. Crawford NM. 1995. Nitrate: nutrient and signal for plant growth. *Plant Cell* 7:859–68
 25. Criqui MC, Durr A, Parmentier Y, Marbach J, Fleck J, Jamet E. 1992. How are photosynthetic genes repressed in freshly-isolated mesophyll protoplasts of *Nicotiana sylvestris*? *Plant Physiol. Biochem.* 30:597–601
 26. Crowell DN, Amasino RM. 1994. Cytokinins and plant gene expression. See Ref. 112a, pp. 233–42

27. Curtis PS, Vogel C, Pregitzer KS, Zak DR, Teeri JA. 1995. Interacting effects of soil fertility and atmospheric CO₂ on leaf area growth and carbon gain physiology in *Populus X euroamericana* (Dode) Guinier. *New Phytol.* 129:253–63
28. D'Amico L, Valsasina B, Daminati MG, Fabbrini MS, Nitti G, et al. 1992. Bean homologs of the mammalian glucose-regulated proteins: induction by tunicamycin and interaction with newly synthesized seed storage proteins in the endoplasmic reticulum. *Plant J.* 2:443–55
- 28a. Danon A, Mayfield SP. 1994. Light-regulated translation of chloroplast messenger RNAs through redox potential. *Science* 266:1717–19
29. DeWald DB, Sadka A, Mullet JE. 1994. Sucrose modulation of soybean *Vsp* gene expression is inhibited by auxin. *Plant Physiol.* 104:439–44
30. Dickinson CD, Altabella T, Chrispeels MJ. 1991. Slow-growth phenotype of transgenic tomato expressing apoplastic invertase. *Plant Physiol.* 95:420–25
31. Dieuaidé M, Brouquisse R, Pradet A, Raymond P. 1991. Increased fatty acid β -oxidation after glucose starvation in maize root tips. *Plant Physiol.* 99:595–600
32. Echt CS, Chourey PS. 1985. A comparison of two sucrose synthetase isozymes from normal and *Shrunken-1* maize. *Plant Physiol.* 79:530–36
33. Elamrani A, Gaudillère JP, Raymond P. 1994. Carbohydrate starvation is a major determinant of the loss of greening capacity in cotyledons of dark-grown sugar beet seedlings. *Physiol. Plant* 91: 56–64
34. Farrar JF, Williams JHH. 1991. Control of the rate of respiration in roots: compartmentation, demand, and the supply of substrate. In *Compartmentation of Metabolism*, ed. M Emms, pp. 167–88. London: Butterworths
35. Foyer CH. 1988. Feedback inhibition of photosynthesis through source-sink regulation in leaves. *Plant Physiol. Biochem.* 26(4):483–92
36. Frommer WB, Mielchen C, Martin T. 1994. Metabolic control of patatin promoters from potato in transgenic tobacco and tomato plants. *Life Sci. Adv.* 13:329–34
37. Fu H, Kim SY, Park WD. 1995. High-level tuber expression and sucrose inducibility of a potato *Sus4* sucrose synthase gene require 5' and 3' flanking sequences and the leader intron. *Plant Cell* 7:1387–94
38. Fu H, Park WD. 1995. Sink- and vascular-associated sucrose synthase functions are encoded by different gene classes in potato. *Plant Cell* 7: 1369–85
39. Fukuda H, Komamine A. 1985. Cyto-differentiation. In *Cell Culture and Somatic Cell Genetics of Plants: Cell Growth, Nutrition, Cytodifferentiation, and Cryopreservation*, ed. IK Vasil, pp. 150–212. New York: Academic
40. Gancedo JM. 1992. Carbon catabolite repression in yeast. *Eur. J. Biochem.* 206:297–313
41. Geiger DR. 1976. Effect of translocation and assimilate demand of photosynthesis. *Can. J. Bot.* 54:2337–45
42. Geiger DR, Servaites JC. 1994. Diurnal regulation of photosynthetic carbon metabolism in C₃ plants. *Annu. Rev. Plant Physiol. Plant Mol. Biol.* 45:235–56
43. Geiger DR, Koch KE, Shieh WJ. 1996. Effect of environmental factors on whole plant assimilate partitioning and associated gene expression in the whole plant. *J. Exp. Bot.* In press
44. Giroux MJ, Boyer C, Feix G, Hannah LC. 1994. Coordinated transcriptional regulation of storage product genes in the maize endosperm. *Plant Physiol.* 106:713–22
45. Glasziou KT, Waldron JC, Bull TA. 1966. Control of invertase synthesis in sugar cane: loci of auxin and glucose effects. *Plant Physiol.* 41:282–88
46. Godf DE, Reigel A, Roitsch T. 1995. Regulation of sucrose synthase expression in *Chenopodium rubrum*: characterization of sugar induced expression in photoautotrophic suspension cultures and sink tissue specific expression in plants. *J. Plant Physiol.* 146:231–38
47. Goldschmidt EE, Huber SC. 1992. Regulation of photosynthesis by end-product accumulation in leaves of plants storing starch, sucrose, and hexose sugars. *Plant Physiol.* 99:1443–48
48. Goldschmidt EE, Koch KE. 1996. Source sink relations and carbohydrate economy of citrus. See Ref. 215a, 797–824
49. Gordon AJ, Kessler W. 1990. Defoliation-induced stress in nodules of white clover. II. Immunological and enzymic measurements of key proteins. *J. Exp. Bot.* 41:1255–62
50. Graham IA, Baker CJ, Leaver CJ. 1994. Analysis of the cucumber malate synthase gene promoter by transient expression and gel retardation assays. *Plant J.* 6:893–902
51. Graham IA, Denby KJ, Leaver CJ. 1994. Carbon catabolite repression regulates

- glyoxylate cycle gene expression in cucumber. *Plant Cell* 6:761–72
52. Grierson C, Du JS, Zabala MD, Beggs K, Smith C, et al. 1994. Separate *cis* sequences and *trans* factors direct metabolic and developmental regulation of a potato-tuber storage protein gene. *Plant J.* 5:815–26
 53. Grimes HD, Tranbarger TJ, Franceschi VR. 1993. Expression and accumulation patterns of nitrogen-responsive lipoxigenase in soybeans. *Plant Physiol.* 103:457–66
 54. Halford NG, Vicente-Carbajosa J, Sabelli PA, Shewry PR, Hannappel U, Kreis M. 1992. Molecular analyses of a barley multigene family homologous to the yeast protein kinase gene *SNF1*. *Plant J.* 2:791–97
 55. Harter K, Talke-Messerer C, Barz W, Schäfer E. 1993. Light- and sucrose-dependent gene expression in photomixotrophic cell suspension cultures and protoplasts of rape (*Brassica napus* L.). *Plant J.* 4:507–16
 56. Hattori T, Nakagawa S, Nakamura K. 1990. High-level expression of tuberous root storage protein genes of sweet potato in stems of plantlets grown in vitro on sucrose medium. *Plant Mol. Biol.* 14:595–604
 57. Heim U, Weber H, Bäumlein H, Wobus U. 1993. A sucrose-synthase gene of *Vicia faba* L.: expression pattern in developing seeds in relation to starch synthesis and metabolic regulation. *Planta* 191:394–401
 58. Heineke D, Sonnewald U, Büssis D, Günter G, Leidreiter K, et al. 1992. Apoplastic expression of yeast-derived invertase in potato: effects on photosynthesis, leaf solute composition, water relations, and tuber composition. *Plant Physiol.* 100:301–8
 59. Heineke D, Wildenberger K, Sonnewald U, Willmitzer L, Heldt HW. 1994. Accumulation of hexoses in leaf vacuoles: studies with transgenic tobacco plants expressing yeast-derived invertase in the cytosol, vacuole or apoplasm. *Planta* 194:29–33
 60. Hesse H, Sonnewald U, Willmitzer L. 1995. Cloning and expression analysis of sucrose-phosphate-synthase from sugar beet (*Beta vulgaris* L.). *Mol. Gen. Genet.* 247:515–20
 61. Huang N, Chandler J, Thomas BR, Koizumi N, Rodriguez RL. 1993. Metabolic regulation of α -amylase gene expression in transgenic cell cultures of rice. *Plant Mol. Biol.* 23:737–47
 62. Huber SC. 1989. Biochemical mechanism for regulation of sucrose accumulation in leaves during photosynthesis. *Plant Physiol.* 91:656–62
 63. Huber SC, Huber JL, Chourey PS, Hannah LC, Koch KE. 1995. Sucrose synthase is phosphorylated in vivo in maize leaves. *Plant Physiol.* 108:142
 64. Huff A. 1984. Sugar regulation of plastid interconversions in epicarp of citrus fruit. *Plant Physiol.* 76:307–12
 65. Ishiguro S, Nakamura K. 1994. Characterization of a cDNA encoding a novel DNA binding protein, SPF1, that recognizes SP8 sequences in the 5' upstream regions of genes coding for sporamin and beta-amylase from sweet potato. *Mol. Gen. Genet.* 244:563–71
 66. Jackson SD, Sonnewald U, Willmitzer L. 1993. Cloning and expression analysis of β -isopropylmalate dehydrogenase from potato. *Mol. Gen. Genet.* 236:309–14
 67. Jacquard A, Houssa C, Bernier G. 1994. Regulation of the cell cycle by cytokinins. See Ref. 112a, pp. 197–215
 68. James F, Brouquisse R, Pradet A, Raymond P. 1993. Changes in proteolytic activities in glucose-starved maize root-tips: regulation by sugars. *Plant Physiol. Biochem.* 31:845–56
 69. Jang J-C, Sheen J. 1994. Sugar sensing in higher plants. *Plant Cell* 6:1665–79
 70. Johnson R, Ryan CA. 1990. Wound-inducible potato inhibitor II genes: enhancement of expression by sucrose. *Plant Mol. Biol.* 14:527–36
 71. Jones JR, Schreiber BM, McNeil K, Brenner ML, Foxon G. 1992. Cytokinin levels and oxidase activity during maize kernel development. In *Physiology and Biochemistry of Cytokinins in Plants*, ed. M Kaminek, DWS Mok, E Zazimalova, pp. 235–39. The Hague: Academic
 72. Jouaville LS, Ichas F, Holmuhamedov EL, Camacho P, Lechleiter JD. 1995. Synchronization of calcium waves by mitochondrial substrates in *Xenopus laevis* oocytes. *Nature* 377:438–41
 73. Journet EP, Bligny R, Doucr R. 1986. Biochemical changes during sucrose deprivation in higher plant cells. *J. Biol. Chem.* 261:3193–99
 74. Karrer EE, Rodriguez RL. 1992. Metabolic regulation of rice α -amylase and sucrose synthase genes in planta. *Plant J.* 2:517–23
 75. Kaufman PB, Ghosheh NS, LaCroix JD, Soni SL, Ikuma H. 1973. Regulation of invertase levels in *Avena* stem segments by gibberellic acid, sucrose, glucose, and fructose. *Plant Physiol.* 52:221–28
 76. Kaufman PB, Song I. 1987. Hormones and the orientation of growth. In *Plant*

- Hormones and Their Role in Plant Growth and Development*, ed. PF Davies, pp. 375–92. Dordrecht: Nijhoff
77. Kim SR, Costa MA, An G. 1991. Sugar response element enhances wound response of potato proteinase inhibitor II promoter in transgenic tobacco. *Plant Mol. Biol.* 17:973–83
 78. Kim SY, May GD, Park WD. 1994. Nuclear-protein factors binding to a class-I patatin promoter region are tuber-specific and sucrose-inducible. *Plant Mol. Biol.* 26:603–15
 79. Kindle KL. 1987. Expression of a gene for a light harvesting chlorophyll a/b-binding protein in *Chlamydomonas reinhardtii*: effect of light and acetate. *Plant Mol. Biol.* 9:547–63
 80. King RW, Evans LT. 1991. Shoot apex sugars in relation to long-day induction of flowering in *Lolium temulentum* L. *Aust. J. Plant Physiol.* 18:121–35
 81. Klein RR, Crafts-Brandner SJ, Salvucci ME. 1993. Cloning and developmental expression of the sucrose-phosphate-synthase gene from spinach. *Planta* 190: 498–510
 82. Knight JS, Gray JC. 1994. Expression of genes encoding the tobacco chloroplast phosphate translocator is not light-regulated and is repressed by sucrose. *Mol. Gen. Genet.* 242:586–94
 83. Koch KE, McCarty DR. 1988. Induction of sucrose synthase by sucrose depletion in maize root tips. *Plant Physiol.* 86:35
 84. Koch KE, Nolte KD. 1995. Sugar modulated expression of genes for sucrose metabolism and their relationship to transport pathways. See 104a, pp. 68–77
 85. Koch KE, Nolte KD, Duke ER, McCarty DR, Avigne WT. 1992. Sugar levels modulate differential expression of maize sucrose synthase genes. *Plant Cell* 4:59–69
 86. Koch KE, Xu J, Duke ER, McCarty DR, Yuan CX, et al. 1995. Sucrose provides a long distance signal for coarse control of genes affecting its metabolism. In *Sucrose Metabolism, Biochemistry, and Molecular Biology*, ed. HG Pontis, G Salerno, E Echeverria. Rockville, MD: Am. Soc. Plant Physiol. 14:266–77
 87. Koßmann J, Visser RGF, Müller-Röber BT, Willmitzer L, Sonnewald U. 1991. Cloning and expression analysis of a potato cDNA that encodes branching enzyme: evidence for coexpression of starch biosynthetic genes. *Mol. Gen. Genet.* 230:39–44
 88. Kovtun Y, Daie J. 1995. End-product control of carbon metabolism in culture-grown sugar beet plants: molecular and physiological evidence on accelerated leaf development and enhanced gene expression. *Plant Physiol.* 108:1647–56
 89. Krapp A, Hofmann B, Schäfer C, Stitt M. 1993. Regulation of the expression of *rbcS* and other photosynthetic genes by carbohydrates: a mechanism for the “sink regulation” of photosynthesis? *Plant J.* 3:817–28
 90. Krapp A, Quick WP, Stitt M. 1991. Ribulose-1,5-bisphosphate carboxylase-oxygenase, other Calvin-cycle enzymes, and chlorophyll decrease when glucose is supplied to mature spinach leaves via the transpiration stream. *Planta* 186:58–69
 91. Krapp A, Stitt M. 1994. Influence of high-carbohydrate content on the activity of plastidic and cytosolic isoenzyme pairs in photosynthetic tissues. *Plant Cell Environ.* 17:861–66
 92. Krapp A, Stitt M. 1995. An evaluation of direct and indirect mechanisms for the “sink regulation” of photosynthesis of spinach: changes in gas exchange, carbohydrates, metabolites, enzyme activities and steady-state transcript levels after cold girdling source leaves. *Planta* 195:313–23
 93. Kroymann J, Schneider W, Zetsche K. 1995. Opposite regulation of copy number and the expression of plastid and mitochondrial genes by light and acetate in the green flagellate *Chlorogonium*. *Plant Physiol.* 108:1641–46
 94. Kumar S, Chandra GR, Albaugh GP, Muthukrishnan S. 1985. Regulation of the expression of α -amylase gene by sodium butyrate. *Plant Mol. Biol.* 5: 269–79
 95. Lam H-M, Peng SS-Y, Coruzzi GM. 1994. Metabolic regulation of the gene encoding glutamine-dependent asparagine synthetase in *Arabidopsis thaliana*. *Plant Physiol.* 106:1347–57
 96. Lambers H, Atkin O. 1995. Regulation of carbon metabolism in roots. See 104a, pp. 226–38
 97. Lejeune P, Bernier G, Requier MC, Kinet JM. 1993. Sucrose increase during floral induction in the phloem sap collected at the apical part of the shoot of the long-day plant *Sinapis alba* L. *Planta* 190:71–74
 98. Lindsey K, Yeoman MM. 1985. Dynamics of plant cell cultures. In *Cell Culture and Somatic Cell Genetics of Plants: Cell Growth, Nutrition, Cytodifferentiation, and Cryopreservation*, ed. IK Vasil, pp. 61–101. New York: CRC Academic
 99. Liu XY, Rocha-Sosa M, Hummel S, Willmitzer L, Frommer WB. 1991. A

- detailed study of the regulation and evolution of the two classes of patatin genes in *Solanum tuberosum* L. *Plant Mol. Biol.* 17:1139–54
100. Llernould S, Karamanos Y, Priem B, Morvan H. 1994. Carbon starvation increases endoglycosidase activities and production of “unconjugated N-glycans” in *Silene alba* cell-suspension cultures. *Plant Physiol.* 106:779–84
 101. Loake GJ, Choudhary AD, Harrison MJ, Mavandad M, Lamb CJ, Dixon RA. 1991. Phenylpropanoid pathway intermediates regulate transient expression of a chalcone synthase gene promoter. *Plant Cell* 3:829–40
 102. Lue MY, Lee HT. 1994. Protein phosphatase inhibitors enhance the expression of an α -amylase gene, α Amy3, in cultured rice cells. *Biochem. Biophys. Res. Comm.* 205:807–16
 103. Lugert T, Werr W. 1994. A novel DNA-binding domain in the *Shrunken* initiator-binding protein (ibp1). *Plant Mol. Biol.* 25:493–506
 104. Maas C, Schaal S, Werr W. 1990. A feedback control element near the transcription start site of the maize *Shrunken* gene determines promoter activity. *EMBO J.* 9:3447–52
 - 104a. Madore MM, Lucas WL, eds. 1995. *Carbon Partitioning and Source Sink Interactions in Plants*. Rockville, MD: Am. Soc. Plant Physiol.
 105. Maraña C, García-Olmedo F, Carbonero P. 1990. Differential expression of two types of sucrose synthase-encoding genes in wheat in response to anaerobiosis, cold shock, and light. *Gene* 88:167–72
 106. Martin T, Frommer WB, Salanoubat M, Willmitzer L. 1993. Expression of an *Arabidopsis* sucrose synthase gene indicates a role in metabolization of sucrose both during phloem loading and in sink organs. *Plant J.* 4:367–77
 107. Mason H, DeWald DB, Creelman RA, Mullet JE. 1992. Coregulation of soybean vegetative storage protein gene expression by methyl jasmonate and soluble sugars. *Plant Physiol.* 98:859–67
 108. McCully ME, Canny MJ. 1995. How do real roots work: some new views of root structure. *Plant Physiol.* 109:1–6
 109. McDonnell E, Farrar JF. 1992. Substrate supply and its effect on mitochondrial and whole tissue respiration in barley roots. In *Molecular, Biochemical and Physiological Aspects of Plant Respiration*, ed. H Lambers, LHW van der Plas, pp. 455–62. The Hague: Academic
 110. Miao Z, Gaynor JJ. 1993. Molecular cloning, characterization and expression of Mn-superoxide dismutase from the rubber tree (*Hevea brasiliensis*). *Plant Mol. Biol.* 23:267–77
 111. Miller ME, Chourey PS. 1992. The maize invertase-deficient *miniature-1* seed mutation is associated with aberrant pedicel and endosperm development. *Plant Cell* 4:297–305
 112. Mok MC. 1994. Cytokinins and plant development: an overview. See Ref. 112a, pp. 155–66
 - 112a. Mok WS, Mok MC, eds. 1994. *Cytokinins: Chemistry, Activity, and Function*. Boca Raton: CRC Press
 113. Monroy AF, Schwartzbach SD. 1984. Catabolite repression of chloroplast development in *Euglena*. *Proc. Natl. Acad. Sci. USA* 81:2786–90
 114. Morré DJ, Jones DD, Mollenhauer HH. 1967. Golgi apparatus mediated polysaccharide secretion by outer root cap cells of *Zea mays*. I. Kinetics and secretory pathway. *Planta* 74:286–301
 115. Morris DA, Arthur ED. 1984. An association between acid invertase activity and cell growth during leaf expansion in *Phaseolus vulgaris* L. *J. Exp. Bot.* 35:1369–79
 116. Müller-Röber BT, Koßmann J, Hannah LC, Willmitzer L, Sonnwald U. 1990. One of two different ADP-glucose pyrophosphorylase genes from potato responds strongly to elevated levels of sucrose. *Mol. Gen. Genet.* 224:136–46
 117. Müller-Röber BT, Sonnwald U, Willmitzer L. 1992. Inhibition of the ADP-glucose pyrophosphorylase in transgenic potatoes leads to sugar-storing tubers and influences tuber formation and expression of tuber storage protein genes. *EMBO J.* 11:1229–38
 118. Muranaka T, Banno H, Machida Y. 1994. Characterization of tobacco protein-kinase npk5, a homolog of *Saccharomyces-cerevisiae* *snf1* that constitutively activates expression of the glucose-repressible *suc2* gene for secreted invertase of *Saccharomyces cerevisiae*. *Mol. Cell. Biol.* 14:2958–65
 119. Murray JR, Hackett WP. 1991. Dihydroflavonol and reductase activity in relation to differential anthocyanin accumulation in juvenile and mature phase *Hedera helix* L. *Plant Physiol.* 97:343–51
 120. Murray JR, Smith AG, Hackett WP. 1994. Differential dihydroflavonol reductase transcription and anthocyanin pigmentation in the juvenile and mature phases of ivy (*Hedera helix* L.). *Planta* 194:102–9

121. Musgrave ME. 1994. Cytokinins and oxidative processes. See Ref. 112a, pp. 167–78
122. Nakamura K, Ohto M, Yoshida N, Nakamura K. 1991. Sucrose-induced accumulation of β -amylase occurs concomitant with the accumulation of starch and sporamin in leaf-petiole cuttings of sweet potato. *Plant Physiol.* 96:902–9
123. Nolte KD, Hendrix DL, Radin JW, Koch KE. 1995. Sucrose synthase localization during initiation of seed development and trichome differentiation in cotton ovules. *Plant Physiol.* 109:1285–93
124. Nolte KD, Koch KE. 1993. Companion-cell specific localization of sucrose synthase in zones of phloem loading and unloading. *Plant Physiol.* 101:899–905
125. Ohto MA, Hayashi K, Isobe M, Nakamura K. 1995. Involvement of Ca^{2+} signaling in the sugar-inducible expression of genes coding for sporamin and β -amylase of sweet potato. *Plant J.* 7: 297–307
126. Ohto M, Nakamura K. 1996. Sugar-induced increase of calcium-dependent protein kinases associated with the plasmamembrane in leaf tissues of tobacco. *Plant Physiol.* 109:In press
127. Ohto M, Nakamura-Kito K, Nakamura K. 1992. Induction of expression of genes coding for sporamin and β -amylase by polygalacturonic acid in leaf-petiole cuttings of sweet potato. *Plant Physiol.* 99:422–27
128. Parks BM, Hangarter RP. 1994. Blue light sensory systems in plants. *Cell Biol.* 5:347–53
129. Patrick JW, Offler CE. 1996. Switching of the cellular pathway of post-sieve element transport in roots and stems. *J. Exp. Bot.* In press
130. Paul MJ, Stitt M. 1993. Effects of nitrogen and phosphorus deficiencies on levels of carbohydrates, respiratory enzymes and metabolites in seedlings of tobacco and their response to exogenous sucrose. *Plant Cell Environ.* 16:1047–57
131. Peña-Cortes H, Liu X, Sanchez-Serrano J, Schmid R, Willmitzer L. 1992. Factors affecting gene expression of patatin and proteinase-inhibitor-II gene families in detached potato leaves: implications for their co-expression in developing tubers. *Planta* 186:495–502
132. Peterson CA. 1988. Exodermal Casparian bands: their significance for ion uptake by roots. *Physiol. Plant* 72: 204–8
133. Pharr DM, Stoop JMH, Studer-Feusi ME, Williamson JD, Massel MO, Conkling MA. 1995. Mannitol catabolism in plant sink tissues. See 104a, pp. 180–93
134. Pollock CJ, Farrar J. 1996. Source-sink relations: the role of sucrose. In *Environmental Stress and Photosynthesis*, ed. NR Baker. The Netherlands: Kluwer. In press
135. Pollock CJ, Lloyd EJ. 1978. Acid invertase activity during senescence of excised leaf tissue of *Lolium temulentum*. *Z. Pflanzenphysiol. Bd.* 90:79–84
136. Pollock CJ, Winters AL, Gallagher J, Cairns AJ. 1996. Sucrose and the regulation of fructan metabolism in leaves of temperate gramineae. In *Sucrose Metabolism, Biochemistry, Physiology, and Molecular Biology*, ed. HG Pontis, GL Salerno, E Echeverria, 14:167–78. Rockville, MD: Am. Soc. Plant Physiol.
137. Pryke JA, Bernier G. 1978. Acid invertase activity in the apex of *Sinapis alba* during transition to flowering. *Ann. Bot.* 42:747–49
138. Purvis AC, Rice JD. 1983. Low temperature induction of invertase activity in grapefruit flavedo tissue. *Phytochemistry* 22:831–34
139. Quick PW, Schaffer AA. 1996. Sucrose metabolism in sources and sinks. See Ref. 215a
140. Rebeille F, Bligny R, Martin JB, Douce R. 1985. Effect of sucrose starvation on sycamore (*Acer pseudoplatanus*) cell carbohydrate and Pi status. *Biochem. J.* 226:679–84
141. Reed AJ, Singletary GW. 1989. Roles of carbohydrate supply and phytohormones in maize kernel abortion. *Plant Physiol.* 91:986–92
142. Roberts DM, Harmon AC. 1992. Calcium-modulated proteins: targets of intracellular calcium signals in higher plants. *Annu. Rev. Plant Physiol. Plant Mol. Biol.* 43:375–414
143. Rocha-Sosa M, Sonnwald U, Frommer W, Stratmann M, Schell J, Willmitzer L. 1989. Both developmental and metabolic signals activate the promoter of a class-I patatin gene. *EMBO J.* 8(1):23–29
144. Roitsch T, Bittner M, Godt DE. 1995. Induction of apoplastic invertase of *Chenopodium rubrum* by D-glucose and a glucose analog and tissue-specific expression suggest a role in sink-source regulation. *Plant Physiol.* 108:285–94
145. Rose M, Albig W, Entian KD. 1991. Glucose repression in *Saccharomyces cerevisiae* is directly associated with hexose phosphorylation by hexokinases PI and PII. *Eur. J. Biochem.* 199:511–18
146. Ross HA, Davies HV. 1992. Sucrose metabolism in tubers of potato (*Solanum*

- tuberosum* L.); effects of sink removal and sucrose flux on sucrose-degrading enzymes. *Plant Physiol.* 98:287–93
147. Ruan YL, Patrick JW. 1995. The cellular pathway of postphloem sugar transport in developing tomato fruit. *Planta* 196: 434–44
 148. Sacher JA, Hatch MD, Glasziou KT. 1963. Regulation of invertase synthesis in sugar cane by an auxin- and sugar-mediated control system. *Physiol. Plant.* 16:836–42
 149. Sadka A, Dewald DB, May GD, Park WD, Mullet JE. 1994. Phosphate modulates transcription of soybean *vspB* and other sugar-inducible genes. *Plant Cell.* 6:737–49
 150. Saier MH. 1989. Protein phosphorylation and allosteric control of inducer exclusion and catabolite repression by the bacterial phosphoenol pyruvate: sugar phosphotransferase system. *Microbiol. Rev.* 53:109–20
 151. Salanoubat M, Belliard G. 1989. The steady-state level of potato sucrose synthase mRNA is dependent on wounding, anaerobiosis and sucrose concentration. *Gene* 84:181–85
 152. Salehuzzaman SNIM, Jacobsen E, Visser RGF. 1994. Expression patterns of two starch biosynthetic genes in in vitro cultured cassava plants and their induction by sugars. *Plant Sci.* 98:53–62
 153. Schäfer C, Simper H, Hofmann B. 1992. Glucose feeding results in coordinated changes of chlorophyll content, ribulose-1,5-bisphosphate carboxylase-oxygenase activity and photosynthetic potential in photoautotrophic suspension cultured cells of *Chenopodium rubrum*. *Plant Cell Environ.* 15:343–50
 154. Schaffer AA, Liu KC, Goldschmidt EE, Boyer CD, Goren R. 1986. *Citrus* leaf chlorosis induced by sink removal: starch, nitrogen, and chloroplast ultrastructure. *J. Plant Physiol.* 124:111–21
 155. Schmidt A, Zetsche K. 1990. Regulation of the synthesis of isocitrate lyase and the corresponding mRNA in the green alga *Chlorogonium*. *Bot. Acta.* 103:48–53
 156. Schnarrenberger C. 1990. Characterization and compartmentalization in green leaves of hexokinases with different specificities for glucose, fructose and mannose and for nucleoside triphosphates. *Planta* 181:249–55
 157. Schulte R, Bonas U. 1992. A *Xanthomonas* pathogenicity locus is induced by sucrose and sulfur-containing amino acids. *Plant Cell* 4:79–86
 158. Schuster JR. 1989. Regulated transcriptional systems for the production of proteins in yeast: regulation by carbon source. In *Yeast Genetic Engineering*, ed. PJ Barr, AJ Brike, P Valenzuela, pp. 83–108. London: Butterworths
 159. Shaw JR, Ferl RJ, Baier J, St Clair D, Carson C, et al. 1994. Structural features of the maize *sus1* gene and protein. *Plant Physiol.* 106:1659–65
 160. Sheen J. 1990. Metabolic repression of transcription in higher plants. *Plant Cell* 2:1027–38
 161. Sheen J. 1994. Feedback-control of gene-expression. *Photosynth. Res.* 39: 427–38
 162. Sheu JJ, Jan SP, Lee HT, Yu SM. 1994. Control of transcription and mRNA turnover as mechanisms of metabolic repression of α -amylase gene expression. *Plant J.* 5:655–64
 163. Shih MC, Goodman HM. 1988. Differential light regulated expression of nuclear genes encoding chloroplast and cytosolic glyceraldehyde-3-phosphate dehydrogenase in *Nicotiana tabacum*. *EMBO J.* 7:893–98
 164. Shorrosh BS, Dixon RA. 1992. Molecular characterization and expression of an alfalfa protein with sequence similarity to mammalian ER p72, a glucose-regulated endoplasmic reticulum protein containing active site sequences of protein disulphide isomerase. *Plant J.* 2:51–58
 165. Simko I. 1994. Sucrose application causes hormonal changes associated with potato-tuber induction. *J. Plant Growth Regul.* 13:73–77
 166. Sonnewald U, Brauer M, von Schaeuwen A, Stitt M, Willmitzer L. 1991. Transgenic tobacco plants expressing yeast-derived invertase in either the cytosol, vacuole or apoplast: a powerful tool for studying sucrose metabolism and sink/source interactions. *Plant J.* 1(1): 95–106
 167. Sonnewald U, Lerchl J, Zrenner R, Frommer W. 1994. Manipulation of sink-source relations in transgenic plants. *Plant Cell Environ.* 17:649–58
 168. Sonnewald W, Willmitzer L. 1992. Molecular approaches to sink-source interactions. *Plant Physiol.* 99:1267–70
 169. Springer B, Werr W, Starlinger P, Bennett DC, Zokolica M et al. 1986. The *Shrunken* gene on chromosome 9 of *Zea mays* L. is expressed in various plant tissues and encodes an anaerobic protein. *Mol. Gen. Genet.* 205:461–68
 170. Staswick PE. 1994. Storage proteins of vegetative plant tissues. *Annu. Rev. Plant Physiol. Plant Mol. Biol.* 45:303–22
 171. St. Pierre B, Brisson N. 1995. Induction

- of the plastidic starch-phosphorylase gene in potato storage sink tissue: effect of sucrose and evidence for coordinated regulation of phosphorylase and starch biosynthetic genes. *Planta* 195:339–44
172. Steinbüßl HJ, Zetsche K. 1986. Light and metabolite regulation of the synthesis of ribulase-1,5-bisphosphate carboxylase/oxygenase and the corresponding mRNAs in the unicellular alga *Chlorogonium*. *Planta* 167:575–81
 173. Stepien V, Sauter JJ, Martin F. 1994. Vegetative storage proteins in woody plants. *Plant Physiol. Biochem.* 32:185–92
 174. Stitt M. 1990. Fructose-2,6-bisphosphate as a regulatory molecule in plants. *Annu. Rev. Plant Physiol. Plant Mol. Biol.* 44:153–85
 175. Stitt M, Krapp A, Klein D, Röper-Schwarz U, Paul M. 1995. Do carbohydrates regulate photosynthesis and allocation by altering gene expression? See 104a, pp. 68–77
 176. Stitt M, Sonnwald U. 1995. Regulation of metabolism in transgenic plants. *Annu. Rev. Plant Physiol. Plant Mol. Biol.* 46:341–68
 177. Stitt M, von Schaewen A, Willmitzer L. 1990. "Sink" regulation of photosynthetic metabolism in transgenic tobacco plants expressing yeast invertase in their cell wall involves a decrease of the Calvin-cycle enzymes and an increase of glycolytic enzymes. *Planta* 183:40–50
 178. Sturm A, Chrispeels MJ. 1990. cDNA cloning of carrot extracellular β -fructosidase and its expression in response to wounding and bacterial infection. *Plant Cell* 2:1107–19
 179. Sturm A, Sebkova V, Lorenz K, Hardegger M, Leinhard S, Unger C. 1995. Development- and organ-specific expression of the genes for sucrose synthase and three isozymes of acid β -fructofuranosidase in carrot. *Planta* 195: 601–10
 180. Sung HI, Liu LF, Kao C. 1994. The induction of α -amylase activity by sucrose starvation in suspension-cultured rice cells is regulated by polyamines. *Physiol. Plant.* 91:137–40
 181. Sung SJ, Xu DP, Black CC. 1988. Identification of actively filling sucrose sinks. *Plant Physiol.* 89:1117–21
 182. Takeda S, Mano S, Ohto M, Nakamura K. 1994. Inhibitors of protein phosphatases 1 and 2a block the sugar inducible gene expression in plants. *Plant Physiol.* 106:567–74
 183. Takeuchi A, Matsumoto S, Hayatsu M. 1994. Chalcone synthase from *Camellia sinensis*: isolation of the cDNAs and the organ-specific and sugar-responsive expression of the genes. *Plant Cell Physiol.* 35:1011–18
 184. Tarczynski MC, Jenson RG, Bohnert HJ. 1992. Expression of a bacterial mtlD gene in transgenic tobacco leads to production and accumulation of mannitol. *Proc. Natl. Acad. Sci. USA* 89:2600–4
 185. Tarczynski MC, Jenson RG, Bohnert HJ. 1993. Stress protection of transgenic tobacco by the osmolyte mannitol. *Science* 259:508–10
 186. Theodorou ME, Plaxton WC. 1993. Metabolic adaptations of plant respiration to nutritional phosphate deprivation. *Plant Physiol.* 101:339–44
 187. Thomas BR, Rodriguez RL. 1994. Metabolite signals regulate gene expression and source/sink relations in cereal seedlings. *Plant Physiol.* 106:1235–39
 188. Thomas BR, Terashima M, Katoh S, Stoltz T, Rodriguez RL. 1995. Metabolic regulation of source-sink relations in cereal seedlings. See Ref. 104a, pp. 78–90
 189. Deleted in proof
 190. Topping JF, Leaver CJ. 1990. Mitochondrial gene expression during wheat leaf development. *Planta* 182:399–407
 191. Tran Thanh Van K. 1980. Control of morphogenesis by inherent and exogenously applied factors in thin cell layers. In *International Review of Cytology 11A: Perspectives in Plant Cell and Tissue Culture*, ed. IK Vasil, pp. 175–94. New York: CRC Academic
 192. Trumbly RJ. 1992. Glucose repression in the yeast *Saccharomyces cerevisiae*. *Mol. Microbiol.* 6:15–21
 193. Tsukaya H, Ohshima T, Naito S, Chino M, Komeda Y. 1991. Sugar-dependent expression of the CHS-A gene for chalcone synthase from petunia in transgenic *Arabidopsis*. *Plant Physiol.* 97:1414–21
 194. Van Oosten JJ, Besford RT. 1994. Sugar feeding mimics effect of acclimation to high CO₂: rapid downregulation of Ru-BisCO small subunit transcripts but not of the large subunit transcripts. *J. Plant Physiol.* 143:306–12
 195. Vaulont S, Kahn A. 1994. Transcriptional control of metabolic regulation genes by carbohydrates. *FASEB J.* 8:28–35
 196. Vincentz M, Moureaux T, Leydecker MT, Vaucheret H, Caboche M. 1993. Regulation of nitrate and nitrite reductase expression in *Nicotiana plumbaginifolia* leaves by nitrogen and carbon metabolites. *Plant J.* 3:315–24
 197. Visser RGF, Vreugdenhil D, Hendriks

- T, Jacobsen E. 1994. Gene-expression and carbohydrate content during stolon to tuber transition in potatoes (*Solanum tuberosum*). *Physiol. Plant.* 90:285–92
198. von Schaewen A, Stitt M, Schmidt R, Sonnewald U, Willmitzer L. 1990. Expression of yeast-derived invertase in the cell wall of tobacco and *Arabidopsis* plants leads to accumulation of carbohydrate and inhibition of photosynthesis and strongly influences growth and phenotype of transgenic tobacco plants. *EMBO J.* 9:3033–44
199. Wardlaw IF. 1990. The control of carbon partitioning in plants. *New Phytol.* 116:341–81
200. Webster PL, Henry M. 1987. Sucrose regulation of protein synthesis in pea root meristem cells. *Environ. Exp. Bot.* 27:253–62
201. Wen IC, Sherman WB, Koch KE. 1995. Heritable pleiotropic effects of the nectarine mutant from peach. *J. Am. Soc. Hort. Sci.* 120:721–25
202. Wenzler HC, Mignery GA, Fisher LM, Park WD. 1989. Analysis of a chimeric class-I patatin-GUS gene in transgenic potato plants: high-level expression in tubers and sucrose-inducible expression in cultured leaf and stem explants. *Plant Mol. Biol.* 12:41–50
203. Willemoës JG, Beltrano J, Montaldi ER. 1988. Diagravitropic growth promoted by high sucrose contents in *Paspalum vaginatum* and its reversion by GA. *Can. J. Bot.* 66:2035–37
204. Williams JHH, Winters AL, Farrar JF. 1992. Sucrose: a novel plant growth regulator. In *The Molecular, Biochemical and Physiological Aspects of Plant Respiration*, ed. H Lambers, LHW van der Plas, pp. 463–69. The Hague: Academic
205. Winters AL, Gallagher J, Pollock CJ, Farrar JF. 1995. Isolation of a gene expressed during sucrose accumulation in leaves of *Lolium temulentum* L. *J. Exp. Bot.* 46:1345–50
206. Winters AL, Williams JHH, Thomas DS, Pollock CJ. 1994. Changes in gene expression in response to sucrose accumulation in leaf tissue of *Lolium temulentum* L. *New Phytol.* 128:591–600
207. Wu LL, Mitchell JP, Cohn NS, Kaufman PB. 1993. Gibberellin (GA₃) enhances cell wall invertase activity and mRNA levels in elongating dwarf pea (*Pisum sativum*) shoots. *Int. J. Plant Sci.* 154(2): 280–89
208. Wu LL, Song I, Karupphian N, Kaufman PB. 1993. Kinetic induction of oat shoot pulvinus invertase mRNA by gravistimulation and partial cDNA cloning by the polymerase chain reaction. *Plant Mol. Biol.* 21(6):1175–79
209. Xu J. 1995. *Cloning and molecular characterization of sugar and developmental regulation in a maize invertase gene family*. Ph.D. thesis, Univ. Florida. 123 pp.
210. Xu J, Pemberton GH, Almira EC, McCarty DR, Koch KE. 1995. The *Ivr1* gene for invertase in maize. *Plant Physiol.* 108:1293–94
211. Yang Y, Kwon HB, Peng HP, Shih MC. 1993. Stress responses and metabolic regulation of glyceraldehyde-3-phosphate dehydrogenase genes in *Arabidopsis*. *Plant Physiol.* 101:209–16
212. Yelenosky G, Guy CL. 1977. Carbohydrate accumulation in leaves and stems of ‘Valencia’ orange at progressively colder temperatures. *Bot. Gaz.* 138:13–17
213. Yokoyama R, Hirose T, Fujii N, Aspuria ET, Kato A, Uchimiya H. 1994. The rolC promoter of *Agrobacterium rhizogenes* Ri plasmid is activated by sucrose in transgenic tobacco plants. *Mol. Gen. Genet.* 244:15–22
214. Yu SM, Kuo YH, Sheu G, Sheu YJ, Liu LF. 1991. Metabolic derepression of α -amylase gene expression in suspension-cultured cells of rice. *J. Biol. Chem.* 266:21131–37
215. Zabaleta E, Oropeza A, Jiménez B, Salerno G, Crespi M, Herrera-Estrella L. 1992. Isolation and characterization of genes encoding chaperonin 60 β from *Arabidopsis thaliana*. *Gene* 111:175–81
- 215a. Zamski E, Schaffer AA, eds. 1996. *Photoassimilate Distribution in Plants and Crops: Source-Sink Relationships*. New York: Dekker
216. Zinselmeier C, Westgate ME, Schussler JR, Jones RJ. 1995. Low water potential disrupts carbohydrate metabolism in maize (*Zea mays* L.) ovaries. *Plant Physiol.* 107:385–91